

SIERRA CLUB RAIL TRANSPORTATION STATEMENT

AUGUST 2023



SIERRA CLUB RAIL TRANSPORTATION STATEMENT

Update to statement by Rail Policy Subcommittee of Chapter Transportation Chairs – April 2007

Clyde Anderson
Omaha, NE
Chair, Transportation Issues, Nebraska Chapter-Sierra Club

Alan S. Drake
New Orleans, LA
Sierra Club member

Dave Foster
Salem, VA
Chairman, RAIL Solution

Robert Frampton
Pasadena, CA
Sierra Club California & Angeles Chapter Transportation Committees
Board Member, Rail Passenger Association of California

Katherine Garcia
Washington, DC
Director, Sierra Club Clean Transportation for All Campaign

Tim Gould
Seattle, WA
Chair, Transportation & Land Use Committee, Sierra Club Washington

David Grubb
Cardiff-by-the-Sea, CA
Chair, Sierra Club San Diego Chapter Transportation Committee

Kenyon Karl
Saco, ME
Rail and transit advocate, Sierra Club member

Yassi Kavezade
Riverside, CA
Sierra Club My Generation Campaign

Anne Macquarie
Carson City, NV
Transportation Committee, Sierra Club Toiyabe Chapter; Co-Chair,
Nevada Rail Coalition

Steven Sondheim
Chicago, IL
Rail and transit advocate, Sierra Club member

Michael Testerman
Richmond, VA
RAIL Solution, Virginia Rail Policy Institute

Robert Wasson
Raleigh, NC
Rail and transportation advocate, Sierra Club member

Tom and Lael White
Mountlake Terrace, WA
Climate Rail Alliance

Brian Yanity
Fullerton, CA
Sierra Club California & Angeles Chapter Transportation Committees
Vice President-South, Rail Passenger Association of California

PHOTO FRONT COVER:
AMTRAK COAST STARLIGHT (LOS ANGELES - SEATTLE)

PHOTO THIS PAGE:
UNION PACIFIC GOING THROUGH PALM SPRINGS



Table of Contents

SUMMARY AND RECOMMENDATIONS	1
RAIL IS ESSENTIAL FOR THE FIGHT AGAINST CLIMATE CHANGE	4
RAIL ELECTRIFICATION	8
RAILROADS AND ENVIRONMENTAL JUSTICE	15
Past inequities in railroad development and operations	
Freight rail impacts	
Railroad rights-of-way and environmental justice	
Universal Basic Mobility	
Transportation planning, social and environmental equity, and rail advocacy	
FREIGHT RAIL	25
Roll-on/roll-off, new forms of intermodal freight rail	
Rail for “light freight”: mail and smaller package handling	
Class I rail corporations’ monopolistic practices skew freight away from rail, plus governments’ general-fund spending for highways skews everything towards trucking	
Railroad as a business	
Are railroads a public utility, or should they be?	
Working with the railroad system we have	
Railroad labor	
PASSENGER RAIL	29
State-supported Amtrak routes	
High speed rail	
Regional/commuter rail	
Rail transit	
RAILROAD TRAINING AND EDUCATION	37
NEXT STEPS- HOW THE SIERRA CLUB CAN ADVOCATE FOR RAIL TRANSPORTATION ...	38
Public investment for rail capacity expansion	
Near Term Focus: Infrastructure Investment and Jobs Act (2021), Inflation Reduction Act (2022)	
Medium to long-term Federal rail legislation and policy	
REFERENCES	45

The Sierra Club is America's largest and most influential grassroots environmental organization, with millions of members and supporters. Inspired by nature, we work together to protect our communities and the planet.

SIERRA CLUB POLICY IS IN SUPPORT OF RAIL TRANSPORTATION:

<https://www.sierraclub.org/policy/transportation>

The Sierra Club supports transportation policy and systems that:

- minimize the impacts on and use of land, airspace and waterways, minimize the consumption of limited resources, including fuel, and reduce pollutant and noise emissions;
- provide everyone, including pedestrians, bicyclists and transit users, with adequate access to jobs, shopping, services and recreation;
- provide adequate and efficient goods movement and substitute local goods for those requiring long distance movement, where feasible;
- encourage land uses that minimize travel requirements;
- strengthen local communities, towns and urban centers, and promote equal opportunity;
- eliminate transportation subsidies which handicap achievement of the above goals; and ensure vigorous and effective public participation in transportation planning.

TRANSIT

"...important are.. light rail and heavy rail (as corridor trips increase) -all electrified wherever feasible. Rail systems are most effective in stimulating compact development patterns, increasing public transit patronage and reducing motor vehicle use."

INTERCITY RAIL

"Amtrak and high speed intercity rail, which afford comparable city center to city center access times, or which offer comparable overnight convenience, are preferred to air travel because they save energy, use less land, cut noise and pollutant emissions, and allow some airports to be closed. Therefore, new or improved rail facilities, and electronic communications, are preferred to new or expanded airports. Discourage private aviation to reduce noise impacts on urban and natural areas."

FREIGHT

"Freight railroads, especially electrified, are preferred over highway or air freight to save energy and land, and cut noise and pollutant emissions."

FINANCING AND SUBSIDIES

"Federal, state, and local subsidies should be provided to those systems (walking, bicycling, public transit, passenger and freight railroads and ferries) and equipment that go further toward achieving accessibility, convenience, efficiency, cleanliness and equity goals, and denied to the other modes."

Identification of Problem and Rationale for this Document

Effective rail transportation is essential to avert the worst effects of human-caused climate change. Increasing the mode share of passenger and freight transportation to rail will result in many environmental, economic and social benefits. Rail transportation is inherently much more energy efficient than road transport, especially for freight. Shifting to rail not only has environmental benefits but economic ones as well. Reducing one of the basic factors of production

– transportation – reduces the costs of virtually every sector of the economy, thereby increasing sustainability. Electrifying railroad operations will further increase these benefits. Therefore, improving passenger and freight rail transportation needs to be a national priority for the US. The purpose of this document is to inform the public about how rail is a sustainable transportation solution, and to provide a guide to action to improve the nation's railroads.

Summary and Recommendations

Effective rail transportation is in the best interest of the nation and the planet. The U.S. railroad network is under-utilized, and we should expect more benefits from it. Current rail policies that shortchange the public interest deny Americans the compelling energy, economic, and environmental benefits inherent in moving as much

freight and passengers by rail as possible. Increasing rail and transit mode share, and moving away from our current heavy emphasis on the road and air modes of transportation, will bring many environmental, economic and social benefits.

Trains are too-often an unsung, but essential, solution to the climate emergency. The inherent energy efficiency of rail transportation means that it is the most climate-friendly form of powered transportation over land. Rail generates only about one-fifth to one-third of the emissions of equivalent road transportation (compared on a ton-mile basis, and often even less on a passenger-mile basis). Nationwide, road transportation is responsible for 82% of transportation greenhouse gas (GHG) emissions; while rail is responsible for 2%. Electrifying railroads will further reduce their GHG emissions and more than triple their energy efficiency. The climate crisis solution lies in using rail transportation far more than we do and utilizing it in innovative ways. Rapid change in transportation priorities to favor rail transportation can be a fast and effective climate emergency response.

Increasing the mode share of rail will require upgrading existing railroad corridors, especially those which parallel major highways. Faster, higher-performance and higher capacity rail lines will attract more passengers and time-sensitive freight. These upgrades include track replacement and upgrading for higher speeds, adding double – or triple mainline tracks, new or extended sidings, and road-rail grade separation projects. A great improvement in rail service ultimately involves large infrastructure (e.g., track, signal, bridge) projects to configure existing lines to more effective utilization. However, the change in transportation emphasis from highway to rail should start immediately. Infrastructure projects and associated increases in service can be pursued incrementally. There is no need to wait for the completion of a large-scale construction plan. Factoring in all costs (economic, environmental, social, etc.), it is too expensive to build and maintain new roads when improved rail transportation can be developed to more economically handle the same throughput (equivalent amount of passenger and freight transportation for lower cost). Road vehicle electrification is critical, but increasing the number of electric vehicles is only part of the solution to transportation congestion and GHG emissions. There is a definite need to electrify all forms of transportation to the greatest extent possible, and to power it with renewable energy. The far greater energy efficiency of rail is the key consideration, given the immense amount of new electric power generation that will be needed to electrify road vehicles. Due to their lower coefficient of friction, rail alternatives utilize less than a third (and often much less) of the energy of the equivalent rubber-tired alternatives driving on roads. Electric trains powered directly by the grid also lessen

the need for batteries, and the environmental impacts of their manufacturing and disposal.

Implementing improved rail services is an important part of the solution to both transportation equity and climate challenges. Well planned, robust passenger and freight rail operations provide benefits such as good jobs, equitable mobility, health and safety, reduced greenhouse gas emissions, reduced traffic congestion, and reduced damage to highway infrastructure. The rail safety record is also substantially better than that of highway (although both rail and highway safety can and should be made safer). All levels of government need to recognize the importance of robust rail transportation for both passenger and freight. In the near term, cities, counties, states and tribes can leverage grant opportunities such as those offered by the Infrastructure Investment and Jobs Act (Bipartisan Infrastructure Law) of 2021. Because most federal grant opportunities require matching funds, it is important for these state and local levels of government to have well-developed project plans that are ready for construction when funding becomes available.

RECOMMENDATIONS

Passenger rail

To effectively compete with automobiles in time and convenience, passenger train service must be appropriately fast, frequent, safe, and reliable. Rail transit and regional passenger rail service must be convenient for travel at all times of day or night, not for just commuting to and from the city center for the beginning and end of business hours on weekdays.

The Federal, state and local governments need to invest much more in capital projects that will increase rail system capacity and reliability, and open new (or re-open) new passenger rail services.

More crews and equipment are needed to maintain existing Amtrak, state, regional and local passenger rail service, and for long-overdue expansion of service. A national program of passenger rail equipment manufacturing is likewise much needed. Amtrak, states and regional agencies should collectively order new rail cars and locomotives to accommodate anticipated expansion of service. Initially this need includes at least 1,000 passenger railcars, along with a large procurement of new locomotives and electric multiple units (EMUs). The economy of scale for rail equipment manufacturing would bring costs down, create thousands of jobs, and build up rail manufacturing capacity and expertise for U.S. industry.

Land-use policy needs to encourage and plan for residential and commercial development around rail stations, both local rail transit or regional and intercity rail.

Freight rail

Sierra Club recommends that intermodalism, and mode shift from truck to rail, be given top priority at the U.S. Department of Transportation (DOT), state DOTs, along with regional and local transportation agencies. Government at all levels must take an intermodal approach to transportation policies to assure that public and private investments are made in a manner to encourage freight traffic to move via the safest, most energy efficient, and cost-effective mode. Local freight rail service needs to be maintained: it is critical to both rural and urban local economies.

Passenger rail advocates' and freight railroad customer activism against so called 'Precision Scheduled Railroading', and other ways the large railroad companies are maximizing profit at the expense of safety, passenger trains and freight shippers, must also be framed in the context of the climate emergency. Railroad cost-cutting leads to a decline in rail freight market share, and thus more truck traffic on the highways. This also increases GHG emissions from freight transport. The freight railroads need to be compelled by regulation to act more in the public interest, not only for the sake of reliable train service but also for the planet.

Rail-oriented freight development, similar to rail or transit-oriented residential development, needs to be studied and promoted by Federal, state, and local governments. In particular, public policy and planning should actively encourage freight rail as an alternative to truck drayage between the nation's ports and inland destinations. With frequent short- and medium-haul freight rail shuttle trains, much of this freight presently moved exclusively by highway may be shifted to rail, to reduce highway congestion and pollution.

Rail labor and education

The major North American railroads have been treating their workers poorly for too long, and have been laying off far too many in recent years. The current labor deficit, together with the anticipated increased utilization of rail, indicates a great need to increase the size of the skilled railroad workforce, and to improve wages and working conditions.

The USDOT and Federal Railroad Administration (FRA) should develop a comprehensive program to train and educate current U.S. railroad personnel in planning, designing and operating fast, frequent, reliable, and convenient rail passenger and freight service. This increased need for a skilled workforce can be met by providing more railroad engineering and operations programs at universities and trade school.

- The Federal Railroad Administration should support 'Rail Tech Hubs'. Such a trackside facility could host:
- High-end manufacturing of electric locomotives and rail equipment ('rail industrial park' for several companies)
- Sites for zero-emissions electric railroad technology demonstrations
- University railroad engineering and research programs
- Railroad employee technical training programs

A Rail Tech Hub could provide high-paying manufacturing jobs in the green technology sector, by attracting companies who manufacture zero-emissions electric locomotives, and intermodal railcars which reduce pollution by shifting more freight from truck to rail, and other technologies.

Rail electrification

The Sierra Club recommends that the Federal government establish a program with the nation's electric utilities and railroads to implement rail electrification nationwide. Electrified rail in heavily-polluted 'non-attainment' areas where trackside communities have been most heavily affected by diesel locomotives, should be a priority for a national rail electrification program.

Federal railroad policy reform

As long as freight and passenger rail need to share the same track, the existing standards for providing preference on the rails for passenger trains over freight trains must be better enforced. This is an issue that is before the Surface Transportation Board (STB).

European-style 'open access' railroad policies need to be explored for the U.S., to enable nondiscriminatory access to the national rail network by a wide variety of freight and passenger rail operators.

[See Section 8. Next Steps: How the Sierra Club Can Advocate for Rail Transportation]

Rail is Essential for the Fight Against Climate Change

Two important elements of a strategy to achieve a climate emergency solution must be:

- To devote all resources necessary for developing an extensive national rail network designed for fast, frequent, reliable freight and passenger trains.
- To limit resources devoted to highways only to maintenance and repair (devoting resources to adding highway capacity would be counterproductive).

Stopping human-caused climate damage requires, in the transportation sector, a variety of solutions, including a substantial shift from highway to rail transportation. Any transportation provided on a railroad, passenger or freight, will reduce greenhouse gas emissions by at least two-thirds per passenger- or ton-mile compared to equivalent road transportation (often significantly more). Rail transport has additional benefits for mitigating climate impacts by its beneficial land use efficiency aspects. Passenger rail transport promotes more transit-oriented development, the very kind of walkable land use patterns that reduce GHG emissions. Evidence from metropolitan areas across the U.S. and the world show that compact land use patterns are associated with dramatically less GHG emissions per capita compared with sprawling automobile-oriented land use patterns¹.

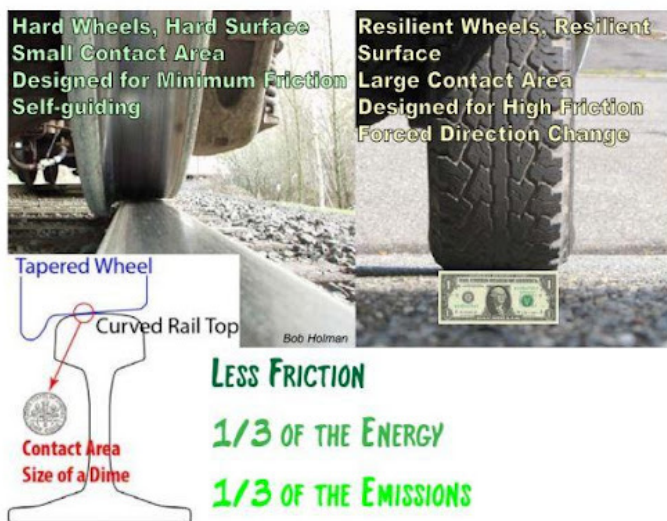

DIAGRAM BY THOMAS WHITE, VTD RAIL CONSULTING

US rail transportation in its current form is sorely inadequate, particularly when considering the need to drastically reduce transportation emissions in response to the impending climate emergency. Passenger rail transportation is particularly inadequate to achieve this

goal. The operation of a single train a day on a route does little to generate ridership. Long schedules and unreliable service add to the problem. Rail freight transportation as it is now conducted is also inadequate for the needed GHG reduction. Rapid extensive mode shift from highway to rail to the greatest extent possible is essential for mitigating climate change. The low friction of smooth steel wheels rolling on smooth steel rails allows rail transportation to emit no more than a third of the greenhouse gas emissions of road vehicles.

There is too often a mistaken perception in the U.S. that “everyone knows trains are big, slow, have polluting diesel locomotives, and carry coal, oil, and other freight that contributes to climate change”. In most of the country, if there is a train for people to ride, it is often not a viable alternative to driving. However, we must consider that:

- Trains use at least two-thirds less energy (fuel) than highway transportation and produce at least two-thirds fewer greenhouse gas emissions for the equivalent ton-mile of freight moved. For electrified rail, the emissions reductions are even more dramatic, with the equivalent of propulsion energy being only 1/5th to 1/10th that of diesel.
- Currently, road transportation produces 82% of transportation greenhouse gas emissions in the US. Rail transportation produces 2%².

In recent years, railroads have been introducing new diesel locomotives, which are in compliance with the U.S. Environmental Protection Agency’s environmental standards for reduced criteria pollutant emissions³. The six criteria pollutants are carbon monoxide, ground-level ozone, lead, nitrogen dioxide, particulate matter, and sulfur dioxide. Trucking is sometimes described as allegedly “cleaner” than rail based on the premise that trucking is going to Tier 4 engines faster than the railroad industry is. Of course, “cleaner” applies to criteria emissions only. Tier 4 truck standards do not reduce GHG emissions significantly, and do not change the fact that trucks will continue to have vastly greater GHG emissions (per ton-mile moved) compared to rail transportation.

When a route is configured for fast, frequent, reliable passenger service, the efficiency and reliability of the freight service also increases concurrently. Configuration

1. <https://www.brookings.edu/research/we-cant-beat-the-climate-crisis-without-rethinking-land-use>

2. <https://www.epa.gov/greenvehicles/fast-facts-transportation-greenhouse-gas-emissions>

3. <https://www.epa.gov/regulations-emissions-vehicles-and-engines/regulations-emissions-locomotives>

Energy intensity of different transport modes

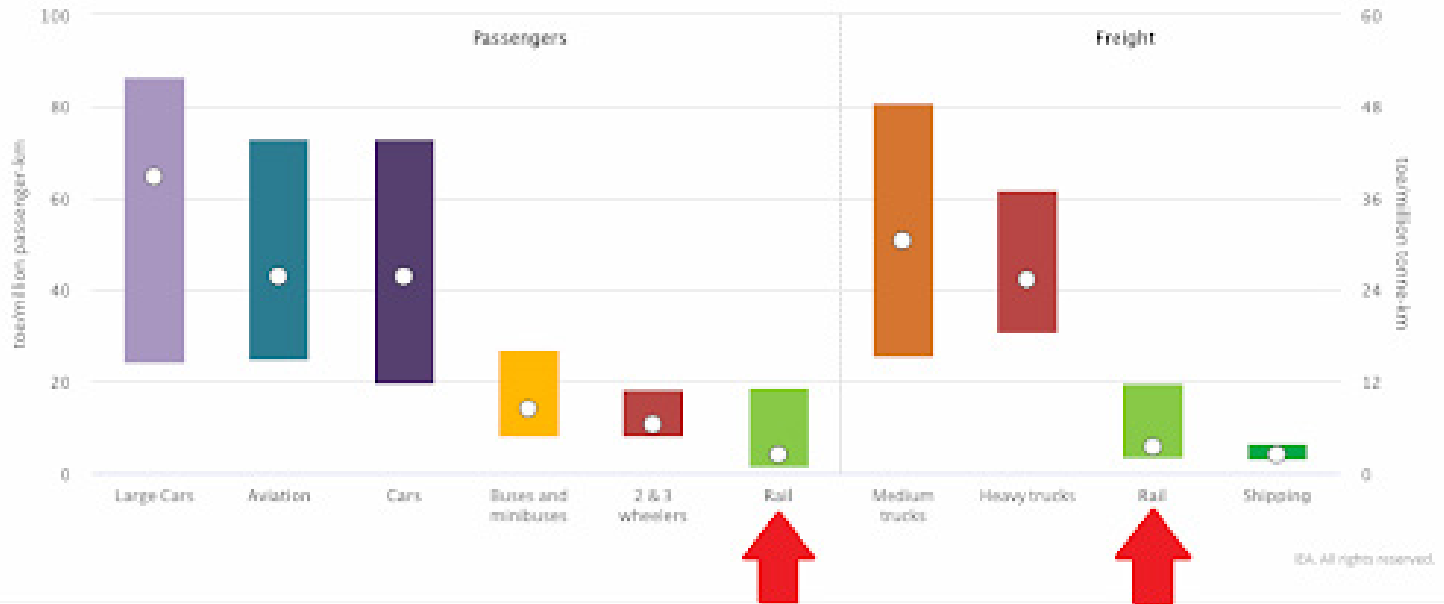

GRAPH: INTERNATIONAL ENERGY AGENCY

of a route for increased passenger service prepares it for fast, reliable intermodal service over short, medium and long distances, which also benefits freight rail. Such intermodal service is used in Europe, particularly through the Alps, to reduce the volume of truck transportation on highways. In North America, other railroad operators who might want to offer such intermodal service should be given equal access to the national network owned by the largest major railroads (designated as Class I), since intermodal service is a vital climate emergency strategy.

Many European countries have instituted policies to encourage rail transportation as a major emissions-reduction strategy⁴. In Europe, a trip on an electric intercity train has 1/4th to 1/8th the GHG emissions per passenger as flying the same distance, depending on the ‘carbon-intensity’ of a region’s particular mix of electricity sources. As part of its climate goals, the German government has established a goal to double train passenger ridership by 2030. Towards this end, new low-cost monthly passes were introduced for unlimited rides on regional rail and bus lines across the country. As described by German national rail carrier DB “Strong Rail” strategy⁵:

No other motorized transport today is as climate-friendly as the rail system. In addition, no other means

of transport is as electromobile – and therefore as low in greenhouse gases and pollutants – as rail, which holds the largest market share of e-mobility in Germany. No other mass transport can achieve a 100% share of renewable energies as quickly – by 2038, we will have converted our traction current in Germany to 100% ecopower. A strong rail system is therefore an essential prerequisite for meeting the climate protection targets of the Federal Government and the EU, because a reduction in emissions in the transport sector cannot be achieved without a massive shift in the mode of transport towards the climate-friendly rail system. Strong Rail is a crucial beacon of hope for our climate. In concrete terms, the shift in the mode of transport and other climate protection measures through Strong Rail means: annual savings of up to 10.5 million tons of CO₂ per year in the transport sector in Germany.

The government of India has a goal to increase freight rail’s mode share from the current 27% to 45% by 2030, with help from new all-electric dedicated freight rail corridors⁶. This part of the government’s national goals to reduce GHG emissions and reliance on imported fuel, while freeing up capacity for more passenger trains on existing mainlines.

4. <https://www.washingtonpost.com/climate-solutions/interactive/2022/europe-trains-planes-lower-emissions>

5. <https://ir.deutschebahn.com/en/db-group/strategy/unsere-strategie-starke-schiene>

6. “Indian transport infrastructure: putting wheels on the elephant”, *The Economist*, March 18, 2023.

Carbon footprint of travel per kilometer, 2018

The carbon footprint of travel is measured in grams of carbon dioxide-equivalents¹ per passenger kilometer. This includes the impact of increased warming from aviation emissions at altitude.

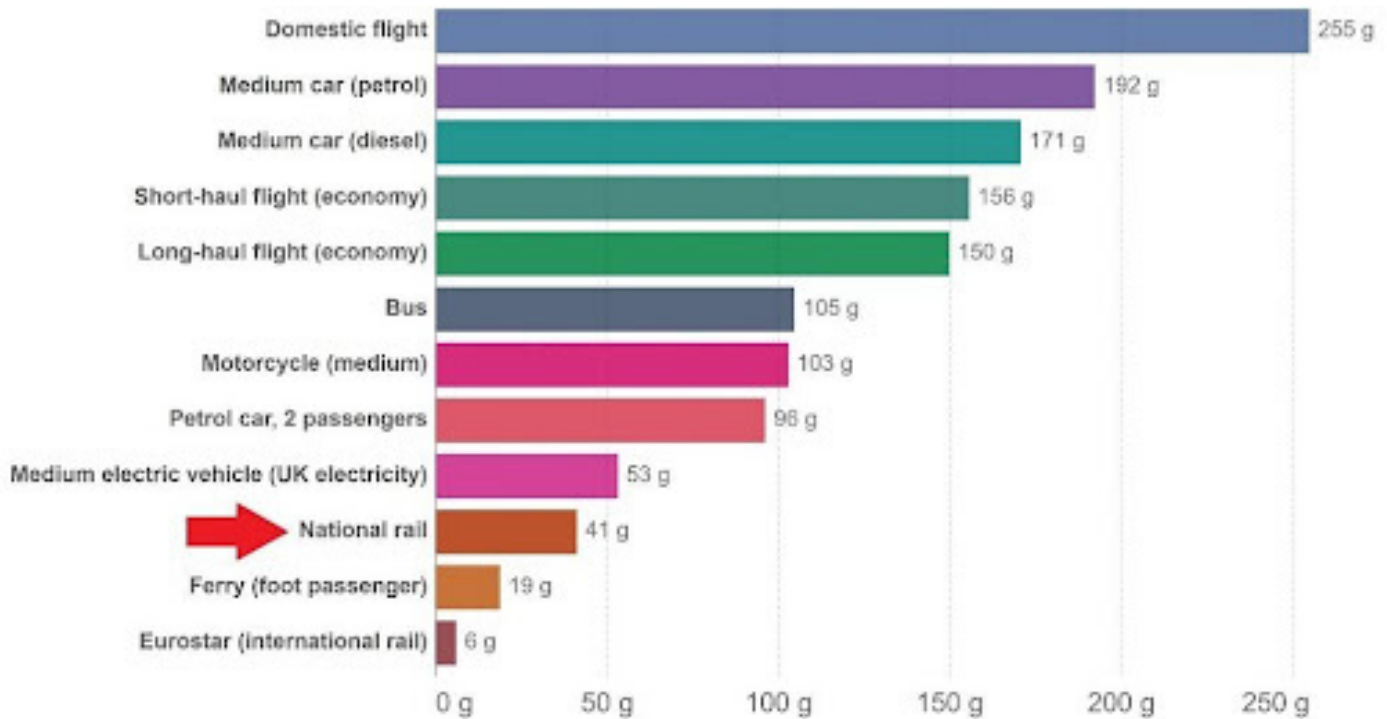

Source: UK Department for Business, Energy & Industrial Strategy. Greenhouse gas reporting: conversion factors 2019. CC BY
 Note: Data is based on official conversion factors used in UK reporting. These factors may vary slightly depending on the country, and assumed occupancy of public transport such as buses and trains.

GRAPH FROM OUR WORLD IN DATA - FIGURES SHOWN FOR TRANSPORTATION MODES IN THE UK, WHERE THE NATIONAL RAIL NETWORK IS PARTIALLY ELECTRIFIED (CREATIVE COMMONS CC BY 4.0)⁸

The multi-agency *U.S. National Blueprint for Transportation Decarbonization* was released in January, 2023⁷. The blueprint named “improve efficiency” as one of three key strategies for transportation decarbonization, “by expanding affordable, accessible, efficient, and reliable options like public transportation and rail, and improving the efficiency of all vehicles...”. However, it did little to encourage mode shift of freight movement from truck to rail, and was dismissive of proven rail electrification technology. The blueprint failed to mention the fact that the U.S. stands out as a notable exception worldwide in not having extensive electrified rail operations. A modern electrified rail network (passenger and freight) would act as a ‘force multiplier’ in terms of decarbonization at many levels.

At high occupancy, diesel-powered passenger trains

can typically keep their emissions to below 50 g of CO₂ (e) per passenger-km, or less than half of that of a gasoline-powered car with two passengers. Diesel-powered freight trains can appear to be exceptionally polluting because the power to move the contents of hundreds of railcars (equivalent to hundreds more trucks) is concentrated in one place. However, while railyards and heavily-used tracks can create significant pollution locally, the overall pollution generated is much less compared to moving the same amount of freight on trucks.

The popular belief that trains have limited usefulness is a uniquely American perspective, a result of American politics and business practices, rather than any technical limitation. These political and economic limitations, and public misconceptions, must be overcome so that a transition from road to rail can be made quickly. The U.S. has been a highway-centric society for over 70 years, since the advent of the interstate highway system

7. <https://www.energy.gov/sites/default/files/2023-01/the-us-national-blueprint-for-transportation-decarbonization.pdf>

8. <https://ourworldindata.org/transport>

in 1956. Highway travel, cars and trucks, has been encouraged by federal and state transportation policy, including appropriation of substantial subsidies. Users only pay for a portion of the cost of highways in fuel excise taxes. The rest comes from general taxes such as property, sales, and income tax, and from debt in the form of bonds. Trucks are more heavily subsidized than cars, and trucks cause the overwhelming majority of the damage to highways while contributing a minority of the maintenance cost. Trucks are also provided with specialized infrastructure such as slow traffic lanes and runaway ramps on steep grades. Airlines and barge transport are also subsidized.

Most of the rail network in the U.S. is owned and maintained by private corporations who also own and operate the freight trains running on that network (although in recent years these rail carriers have more often required shippers to supply their own freight cars). With the exception of Amtrak's Northeast Corridor where Amtrak owns and maintains the railway, Amtrak pays the private railroad corporations for the right to operate its passenger trains on their rail network. Some states supplement the Amtrak network with corridor service using state owned and maintained passenger trains run on the private railroad corporations' network. In addition, cities or regional authorities pay for and operate local transit and regional/commuter trains mostly run on the private railroad corporations' network.

According to a 2022 report of the U.S. Government Accountability Office (GAO), "Of the seven largest U.S. freight railroads, six have reported implementing 'precision-scheduled railroading' (PSR), a strategy intended to increase efficiency and reduce costs. While there is no one definition of PSR, stakeholders told us this strategy is associated with fewer staff, longer trains, and more." The railroads claim that they ran longer

trains with the goal of increasing efficiency. However, the GAO report continues, "Railroad unions and customers identified safety and service concerns from this strategy. The Federal Railroad Administration and Surface Transportation Board are both pursuing ways to monitor and address potential effects"⁹.

Passenger rail advocates and freight railroad customers have expressed criticism of PSR as a veiled cost-cutting strategy, without achieving the claimed "increased efficiency". In some ways, this PSR strategy has been at the expense of passenger trains on time schedules and delivery delays for many freight shippers. Also, the Class 1 railroads have not been aggressive in increasing their market share of freight movement. The decline in rail freight market share in search of maximizing rates of return results in more truck traffic on the highways, and this increases GHG emissions significantly. As corporations, railroad companies have the fiduciary responsibility to act in the best interests of the stockholders. That is interpreted to mean making the greatest possible amount of profit. But this method of maximizing profits in the near term is short-sighted. The industry is currently using the term precision-scheduled railroading to represent a process that achieves high profits at the expense of safety and reliability. PSR is a way to minimize the cost of traffic the industry wants and discourage traffic that it doesn't want. For this reason, shipments by rail are typically limited to distances of greater than 700 miles; and rail companies concentrate on shipping entire trainloads of heavy, non-time-sensitive freight, at the expense of loading smaller, allegedly less profitable, shipments into individual freight cars. This strategy thus concedes a large portion of freight movement to the trucking industry by default.

9. <https://www.gao.gov/products/gao-23-105420>

Rail Electrification

Electric trains, powered by overhead catenary wires or third rail, provide the most energy efficient way of rapidly moving large numbers of people or freight over land. A conventional electric train does not have to store its fuel supply onboard or carry its weight. Instead, it takes its energy from an external source, on an as needed basis where the energy goes straight to the traction motors. In addition, with fewer moving parts, electric trains have proved to be much more dependable and easier to maintain than diesel powered trains. Electric trains are zero emissions at the point of use and can use power generated from a wide mix of sources including renewables.



HECTOR RAIL INTERMODAL FREIGHT TRAIN IN GERMANY, PULLED BY BOMBARDIER TRAXX ELECTRIC LOCOMOTIVE (PHOTO: PXHERE.COM, CREATIVE COMMONS CC0)

Electric, zero-emissions rail transportation is in widespread (and growing) use throughout the world. It is a proven technology that is over 140 years old. The world's first commercial electric rail line, built by Werner von Siemens, opened in Lichterfelde, Germany in 1881. Despite being well established, electric trains also have been called a 'future proof' technology. Not only are electric trains quieter, have no emissions at point of use, and have far greater overall energy efficiency, they can also accelerate faster than diesel-powered trains, and have lower operations and maintenance costs. This enables an increased frequency of trains, and thus more capacity for a section of track. In contrast, passenger rail lines relying on diesel-powered trains are limited in their speed, capacity, and capability.

Around the world, there is a documented increase in passenger train ridership following electrification, known as the "sparks effect". This is because electric trains have:

- Increased train speed and frequency due to better acceleration
- Passenger comfort (quieter, smoother ride, no smoke)
- Increased reliability (fewer train breakdowns)
- Lower equipment, operation and maintenance (O&M) costs means passenger railroads can invest more in frequent service.

All-electric locomotives (powered via overhead catenary wire) have an overall energy efficiency of over 90 percent. The world's most powerful locomotives are all-electric. In fact, propulsion power can be more than double that of a diesel locomotive the same size. Due to greater power per unit, one electric freight locomotive can be substituted for two diesel ones. Electric Multiple Units (EMUs) distribute motor power traction along the entire length of the train. This provides superior acceleration compared to electric locomotives hauling unpowered cars, similar to an all-wheel-drive car on a slick roadway. EMUs outperform other passenger trains in every respect: speed, acceleration, passenger comfort, energy consumption, O&M costs, reliability, and lower procurement costs. EMUs can be operated in trains of 6 or 8 cars during rush hours and then be separated into one and two car trains to meet limited demand with frequent service mid-day, evenings and on weekends. The quick re-configuration of consist creates significant operating economies.



Class EF-1 locomotive in Atherton, Montana 1950 (photo by Philip Johnson)

THE MILWAUKEE ROAD WAS RUNNING ELECTRIC LONG-DISTANCE FREIGHT AND PASSENGER TRAINS ON 663 MILES OF ELECTRIFIED TRACK THROUGH THE CASCADES AND ROCKY MOUNTAINS, FROM 1914 TO 1974.

For society to accept massive mode shift from road to rail transportation, electrification of the most heavily-used railroad tracks is key. Pollution and noise impacts to communities alongside tracks and railyards would be effectively mitigated by rail electrification. For a given number of kilowatt hours of electric energy, multiple times the amount of people or freight can be moved on an electric train compared to an electric road vehicle. While zero emissions at the point of vehicle operation, electric vehicles (EVs) still have the need for batteries with materials mined/toxic disposal issues, or rubber tire sourcing causing tropical deforestation, or toxic tire pollution, or any of the myriad problems inherent to road vehicles in general, whether they be electric or powered by internal combustion engines. Unlike aviation, which will be very difficult to move away from petroleum fuels, rail can convert to electricity generated from clean sources in the grid like hydroelectric, wind, solar, and geothermal. Electric trains can use regenerative braking, and directly feed power to the motors. It is also far easier and more energy efficient to electrify trains than trucks, particularly for long-haul trucks which would have to stop to charge every couple hundred miles on long-distance trips.

Most of the industrialized countries have electrified their primary railway routes. China, Russia, India, and South Africa have extensive electrified rail networks powering the majority of their rail traffic, including on long-distance lines. The European Union as a whole has electrified over half of total railroad network miles. India is on track to complete electrification of 100 percent of all mainline railroad tracks in 2024. The International Energy Agency strongly endorses electric rail as a strategy to reduce fossil fuel consumption¹⁰.

RAILROAD ELECTRIFICATION AROUND THE WORLD (BOTH PASSENGER AND FREIGHT COMBINED, AS OF 2022)¹¹

Country	Miles Electrified (approx.)	Percentage Electrified
Ethiopia/Djibouti	470	100%
Armenia	435	100%
Switzerland	3,200	99%
Laos	256	98%
Belgium	1,900	85%
India	34,300	83%
Georgia	800	82%
Italy	8,200	79%
South Korea	2,300	78%
Sweden	7,600	76%
Netherlands	1,400	76%
Japan	12,500	75%
Taiwan	800	73%
Bulgaria	1,800	71%
Portugal	1,100	71%
Austria	2,400	69%
North Korea	2,400	68%
Norway	1,600	68%
Spain	6,900	68%
China	62,000	67%
Poland	7,500	65%
Azerbaijan	790	60%
Bosnia and Herzegovina	350	56%
Germany	14,000	55%
Finland	2,000	55%
France	9,700	54%
Russia	27,200	51%
Morocco	630	49%
South Africa	5,900	47%
Ukraine	5,800	47%
Slovakia	1,000	44%
Turkey	3,400	43%
Uzbekistan	1,600	39%
United Kingdom	3,800	38%
Israel	155	18%
Iran	1,400	17%
United States	1,500	< 1%

10. <https://www.iea.org/fuels-and-technologies/rail>

11. References on rail electrification statistics by country:

<https://www.cia.gov/library/publications/the-world-factbook/fields/2121.html>

http://uic.org/IMG/pdf/synopsis_2015_print_5_.pdf

http://statbel.fgov.be/fr/statistiques/chiffres/circulation_et_transport/transport/ferroviaire/

<https://core.indianrailways.gov.in/>

<https://www.sciencedirect.com/science/article/abs/pii/S0360544221006125>

<https://www.infraestruturasdeportugal.pt/pt-pt/infraestruturas/rede-ferroviaria>

https://en.wikipedia.org/wiki/List_of_countries_by_rail_transport_network_size

The total length of mainline electrified railway in the U.S. is about 1,500 miles. In the Northeast U.S., the Northeast Corridor is electrified for 457 miles between Washington, D.C. and Boston. This includes the Keystone Corridor between Philadelphia and Harrisburg, parts of the SEPTA system around Philadelphia, New Jersey Transit, Metro North and the Long Island Railroad. The Chicago area is served by two regional electric rail lines (the Metra Electric and the South Shore Line). More recently, Denver RTD has constructed a 25-kV electric regional rail system over 54 miles in length. The 39-mile, 50 kV Deseret Power Railway in Colorado and Utah carries coal from a mine to a power plant, and is isolated from the national rail network. A handful of similar isolated electric coal railroads around the country have been shut down in recent years.

Over a century ago the U.S. was the world leader in long-distance freight rail electrification¹². Abandonment of electric mainline freight occurred despite some serious interest in rail electrification in the wake of the 1970s energy crisis. The USDOT and several major railroads embarked on serious studies of mainline, long-distance rail electrification during this period¹³. Electrification as an option was examined as part of the Federal act that allowed the seven bankrupt Northeastern railroads to be restructured into Consolidated Rail Corporation (Conrail), which would go on to abandon the last electrified mainline freight operations in the U.S. in 1982. More recently, Sierra Club has supported the 25kV mainline rail electrification projects for Caltrain (between San Francisco and San Jose) and California High Speed Rail, both currently under construction.

Union Pacific Railroad's comment letter on the 2021 Nevada State Rail Plan (NVSRP) is an example of typical objections raised by the U.S. railroads against the concept of mainline electrification¹⁴:

UPRR finds the inclusion of the "Rail Electrification Council Statement on the Benefits of Rail Electrification for Nevada" as part of the NVSRP to be inappropriate. Beyond the fact that the state does not control rail infrastructure, UPRR would have considerable engineering, safety and operating issues/concerns with electrifying our main line corridors, including -

- Employee safety
- Clearances
- Potential electrical interference with UPRR systems

12. Bill Moyer, Patrick Mazza and the Solutionary Rail team (<http://www.solutionaryrail.org/>). *Solutionary Rail: A people-powered campaign to electrify America's railroads and open corridors for a clean energy future*, October 2016, pp. 8-11.

13. U.S. Department of Transportation, *A Prospectus for Change in the Freight Railroad Industry: a preliminary report*, October 1978: <https://catalog.hathitrust.org/Record/000219500>

14. <https://www.dot.nv.gov/home/showpublisheddocument/19232/637528812963330000>

- Limited ability to utilize the full width and height of right of way due to the required

infrastructure associated with rail electrification and/or electric transmission

UPRR is not evaluating any proposals on electrification of its routes in Nevada. Given the listed concerns, it is unlikely that UPRR would be able to accommodate either electrification for freight or passenger rail service or infrastructure for high voltage transmission within our right of way.

In 2020, the Association of American Railroads (AAR) released a fact sheet titled *Oppose Rail Electrification & Support Sensible Climate Policy*¹⁵, which claimed that rail electrification is too expensive and is unnecessary. However, AAR's position and analysis on rail electrification has been widely criticized by rail experts and economists as unsupported by facts and being too simplistic¹⁶.

The main drawback to electrification is the upfront capital cost of overhead wire and supporting electrical infrastructure. In the case of the recent Caltrain electrification project between San Francisco and San Jose, the cost was about \$14 million/route mile, much higher than the world average. However, many of the reasons for this include limited experience in the U.S. with electric mainline rail technology and its construction. In Germany, for example, the labor pay scales, material costs and environmental regulations are not much different from the U.S., yet the cost of overhead wire catenary and supporting infrastructure is much less (as low as \$2 million/route mile). As quoted in the 2021 report by Transit Matters on regional rail electrification in the Boston area¹⁷:

The cost range for most electrification projects in high income countries is about \$2–4.5 million per route-mile. There are high-end outliers, as in Toronto and California, whose projects have suffered from avoidable mistakes in planning and engineering. India is currently fully electrifying its rail network for less than \$1 million per route-mile, but this is in a country with low labor costs and it would not be fair to assume this would be replicable in a higher-wage country.

The often-repeated assertion that overhead catenary wire is too expensive to install and maintain is not borne out by the evidence of rail operations around the world. It must be emphasized that many of the countries that have electrified their rail networks did so primarily because

15. <https://www.railwayage.com/wp-content/uploads/2021/02/AAR-Electrification-Fact-Sheet.pdf>

16. <https://www.railwayage.com/news/dont-dismiss-freight-rail-electrification>

17. <https://transitmatters.org/blog/rrelectrification>



ELECTRIC FREIGHT TRAINS WERE ONCE A COMMON SIGHT IN AMERICA:
PACIFIC ELECTRIC RAILWAY LOCAL FREIGHT TRAIN PULLED BY ELECTRIC
LOCOMOTIVES IN SOUTH LOS ANGELES, 1953
(PHOTO: PACIFIC ELECTRIC RAILWAY HISTORICAL SOCIETY)

it proved to be more economical than diesel power on heavily-used lines while improving performance, and not for the sake of being zero emissions.

A wide variety of rail operations around the world, from South Africa (which operates all-electric 40,000-ton iron ore trains, twice as heavy than any U.S. freight trains), to India, China, all over Europe, Japan, Korea, etc. have demonstrated that overhead catenary on main lines is overall less expensive than maintaining and operating an all-diesel fleet for an equivalent level of heavy service on main lines. An electric locomotive also can have much greater power per unit than diesel, so fewer locomotives are needed on a multi-locomotive train to do the same job (the world's most powerful locomotives are all electrics). The fuel cost is much less; and since electric locomotives have so many fewer moving parts they are far less costly to maintain. There are costs to maintain a catenary overhead contact system. But, in most cases, the overall maintenance cost of an all-electric, frequently-used railroad line (including the overhead wire maintenance) is significantly less than using diesel power.

Railroad rights-of-way have also been identified as ideal routes for new high-voltage power lines being added to the nation's grid¹⁸. For example, the SOO Green Transmission Line Project is constructing a buried high voltage DC (HVDC) transmission line alongside a railroad track between Mason City, Iowa and Chicago¹⁹. Having this power source available, railroad electrification will be simplified. Large-scale electric energy storage systems can also be co-located with the grid-connected 'traction power substations' which power electric

18. <https://www.solutionaryrail.org>

19. <https://www.soogreenrr.com/soo-green-transmission-line-will-innovate-energy-transportation>

rail lines, benefiting the reliability of both the power grid and the electric trains.

Conventional zero-emissions electric rail technology, utilizing overhead catenary wire, is very well established. There are other zero-emissions rail technologies that are emerging, like advanced battery locomotives for 'yard switching', and hydrogen passenger rail vehicles. However, hydrogen and battery-powered locomotives and trains have a very limited range, and are much more expensive to purchase, operate, and maintain compared to conventional all-electric locomotives using an overhead catenary wire. Also, the source of hydrogen usually is "dirty", that is, derived from fossil fuels. Sierra Club only supports the use of 'green hydrogen' from 100 percent renewable sources²⁰. The energy efficiency of battery-electric, and especially hydrogen-powered, drivetrains is also much less than compared to conventional electric trains, and will remain so due to laws of physics²¹. Even if the hydrogen comes from green sources, it would still require three times the amount of overall energy compared to an electric train connected directly to the grid²².



EXISTING ANAHEIM PUBLIC UTILITIES TRANSMISSION AND DISTRIBUTION LINES,
WITH VOLTAGES SHOWN, SHARING A SECTION OF THE 100'-WIDE LOS ANGELES-
SAN DIEGO AMTRAK PACIFIC SURFLINER LOSSAN DOUBLE-TRACK RAIL CORRIDOR
(PHOTO BY BRIAN YANITY)

According to a recent study by Deutsche Bahn (DB), the 'sweet spot' for battery or hydrogen train would be on lines with light traffic and not high speed, where electric power is not available. The number of watt-hours of energy consumed per seat-mile on a passenger train was estimated to be 20.5 for electric (w/ overhead wire), 43.6 for battery power and 46.2 for hydrogen propulsion²³. The energy density of hydrogen, stored

20. <https://www.sierraclub.org/articles/2022/01/hydrogen-future-clean-energy-or-false-solution>

21. https://riagb.org.uk/RIA/Newsroom/Publications%20Folder/Why_Rail_Electrification_Report.aspx

22. Ibid.

23. <https://www.hsrail.org/events/zero-emissions-rail-propulsion-electrification-batteries-or-hydrogen/>

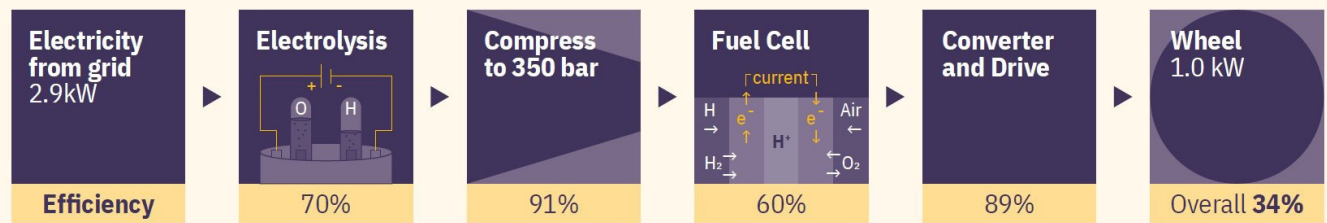

Figure 16 Typical overall efficiency of hydrogen trains

HYDROGEN TRAINS HAVE THE WORST ROUNDTRIP ENERGY EFFICIENCY ON ANY RAIL PROPULSION TECHNOLOGY: IT TAKES 3 TO 4 TIMES THE AMOUNT OF ELECTRICITY TO PRODUCE RENEWABLE HYDROGEN, WHICH WOULD HAVE THE SAME USEFUL TRAIN-PROPULSIVE ENERGY AS POWERING A TRAIN WITH RENEWABLE ELECTRICITY DIRECTLY. [DIAGRAM FROM UK RAILWAY INDUSTRY ASSOCIATION, WHY RAIL ELECTRIFICATION? REPORT, 2021]

onboard at 350 bar, has a volumetric energy storage density 1/12th that of diesel, and current battery technology only 1/20th²⁴. Taking into account energy efficiency, the volumetric energy density of hydrogen powering a train is less than 1/4 that of diesel, and battery about 1/10th that of diesel²⁵.

Hydrogen trains have the worst roundtrip energy efficiency on any rail propulsion technology: it takes 3 to 4 times the amount of electricity to produce renewable hydrogen, which would have the same useful train-propulsive energy as powering a train with renewable electricity directly.

Trains powered by hydrogen or batteries (alone) cannot be a viable solution for long-distance heavy freight and high-speed passenger rail due to laws of physics. A hydrogen locomotive or train will have a limited range, and ‘battery-only’ trains even less: a small fraction of that than the 800 to 1,000 miles typical of a conventional diesel locomotive, and “infinity” for an overhead wire. This has to do with the physics of energy density. The difference is that a freight locomotive must be able to pull many more times its weight (by a factor of up to 100), compared to what a bus or truck must pull. Therefore, the onboard power plant must be at least an order of magnitude larger in size, along with the magnitude of energy stored onboard. The only type of onboard power source that could store enough energy within a locomotive or train to beat diesel is a nuclear reactor. Hydrogen and batteries (alone) will not get even remotely close. Perhaps the biggest advantage of an external electrical source is that a train does not need to expend energy carrying heavy fuel or batteries. On a passenger train, the overhead catenary system (OCS) keeps the power source offboard the train and thus maximizes the space available for passengers. Also, an external source of electricity avoids the

environmental problems of batteries. While use of battery powered locomotives has been proposed in the U.S. as an alternative to new or expanded overhead wire infrastructure, it should be noted that countries all over the world have started and expanded vast electrified rail networks economically without use of any battery trains.

Railroad companies and public agencies have used the vague promise of future development of hydrogen trains as an excuse not to electrify; and hydrogen locomotives are actively promoted by oil and gas companies as a potential market for natural gas²⁶. Compared to conventional electric rail technology, hydrogen trains and locomotives are inherently much more complex and more expensive to maintain, with far more potential points of failure (many of them dangerous considering hydrogen leaks easier than natural gas). Hydrogen-powered fuel cells alone cannot provide enough instantaneous power to accelerate a train, so an onboard battery pack is also needed in addition to the hydrogen tanks, taking up even more space and weight. There have only been about a dozen hydrogen full-sized locomotives ever built, none of which have entered regular commercial service. The Alstom iLint hydrogen multiple unit trains introduced recently to branch line passenger service in Germany have been plagued by reliability problems, particularly in cold weather²⁷. By contrast, there are tens of thousands of electric locomotives operating heavy trains (and many thousands more electric multiple unit trains) around the world each day, very reliably and economically. There are many experienced vendors, manufacturers, etc. around the world who know how to provide reliable and economic electric rail. There are only a handful for hydrogen rail technology, which remains an unproven and expensive technology. In addition to the overall energy efficiency of green hydrogen being very poor, the fresh

24. https://ria.org.uk/RIA/Newsroom/Publications%20Folder/Why_Rail_Electrification_Report.aspx

25. <https://www.hsrail.org/events/zero-emissions-rail-propulsion-electrification-batteries-or-hydrogen/>

26. <https://www.chevron.com/newsroom/2021/q4/caterpillar-bnsf-and-chevron-agree-to-pursue-hydrogen-locomotive-demonstration>

27. <https://www.trains.com/trn/news-reviews/news-wire/hydrogen-powered-trains-struggle-with-winter-weather>

water needed to produce hydrogen by electrolysis may not be in sufficient supply in dry regions. Using seawater as a source would have the same siting issues faced by coastal desalination plants.

A recent report from the state of Baden Wurttemberg in Germany concluded that they will no longer consider hydrogen for rail propulsion, as it is more expensive than battery or hard wire electrification by as much as 80 percent²⁸:

“The positives for hydrogen were: minor impacts upon introduction and during operation, and no changes required to the rail infrastructure. But the negatives were: costly filling stations; low efficiency, high energy consumption and high cost; the possible need to increase the number of trains because the range would not be sufficient for a whole day of travel; limited availability of green hydrogen; and the need to continually resupply the hydrogen filling stations.”

In fact, no one really knows how much a comprehensive green hydrogen infrastructure would cost. It is important for public transportation and infrastructure policy decision makers to acknowledge this fact. Direct electrification with overhead wire is the most energy efficient and economic means of achieving zero emission rail propulsion for high and medium density rail lines. Battery and hydrogen are only practical for light density routes and yard/industrial switching operations. As concluded by a 2021 report by the UK Railway Industry Association²⁹:

Evidence does not support the view that electrification is unnecessary, thanks to hydrogen and battery systems improving rapidly: hydrogen trains are inherently less efficient than electric trains, due to the physical properties of the gas. Expert opinion predicts that battery capability might double by 2035. Yet, whilst this might affect the hydrogen / battery traction mix required for decarbonisation, it is unlikely to change significantly the requirement for electrification.

The laws of nature make electrification a future-proofed technology that is a good investment, offering large passenger, freight, and operational benefits. Furthermore, railways cannot achieve net-zero carbon emissions without a large-scale electrification programme.

Similarly, Network Rail’s 2020 *Traction Decarbonisation Network Strategy* report concluded that, for the currently unelectrified lines in the UK, rail decarbonization requires

electric, hydrogen and battery traction operating on respectively 86%, 9% and 5% of the rail network³⁰.

To achieve near zero GHG emissions from rail, neither battery nor hydrogen trains are a substitute for mainline rail electrification (with conventional overhead catenary wire). They will at best complement electrification for some specialized applications such as freight yard switching or lightly-used branch passenger lines, or in hybrid operation to cover short sections without an overhead wire.

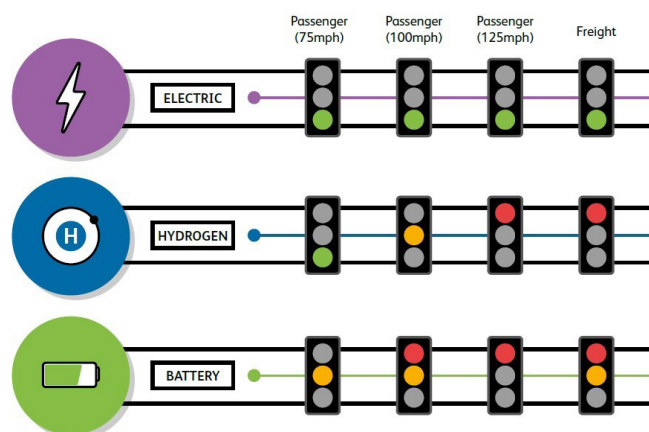

DIAGRAM OF TECHNICAL ABILITIES OF NON-DIESEL RAIL TRACTION TECHNOLOGIES, FROM “TRACTION DECARBONIZATION NETWORK STRATEGY – INTERIM PROGRAMME BUSINESS CASE – EXECUTIVE SUMMARY; NETWORK RAIL, JULY 2020, P. 4³¹”

Hydrogen and battery trains will always be more expensive to purchase, operate, and maintain than conventional all-electric trains and locomotives. This is chiefly because the latter have far fewer moving parts and other components. This also means that they have far fewer points of possible failure (as an overall less complex system), and thus are more reliable than other locomotive types. The operating experience of many railroads around the world show this to be true.

In addition to hydrogen, another alternative to electrification sometimes proposed is to repower diesel locomotives with liquified natural gas (LNG). In November 2017, the Florida East Coast Railway garnered national attention by announcing that it had converted all 28 of its mainline diesels to LNG. They would operate in pairs with an LNG fuel car (tender) sandwiched in between. At the time, this development gave rise to speculation in the industry press that use of LNG in locomotives would become a “paradigm shift”. However, in the ensuing years there has been little follow through. Several Class I railroads have conducted experiments

28. <https://www.hydrogeninsight.com/transport/will-no-longer-be-considered-hydrogen-trains-up-to-80-more-expensive-than-electric-options-german-state-finds/2-1-1338438>

29. https://ria.gov.org/RIA/Newsroom/Publications%20Folder/Why_Rail_Electrification_Report.aspx

30. <https://www.networkrail.co.uk/wp-content/uploads/2020/09/Traction-Decarbonisation-Network-Strategy-Interim-Programme-Business-Case.pdf>

31. <https://www.networkrail.co.uk/wp-content/uploads/2020/09/Traction-Decarbonisation-Network-Strategy-Executive-Summary.pdf>

using LNG in diesel locomotives, but no groundswell of interest has developed. Like hydrogen, LNG cannot be considered a substitute for electrification. LNG has significant identifiable drawbacks:

- It replaces one fossil fuel with another, and is a source of methane emission.
- Note that LNG is typically stored and transported in tanks loaded on vessels as a cryogenic liquid, at temperature of -163°C (-261°F), to increase its density, but making transport and storage more difficult.
- The Federal Railroad Administration has approved design of the LNG tankcar, but rail unions are unenthusiastic about having this large gas bottle coupled directly to their locomotives.
- Protesters have denounced LNG trains as “bomb trains”, which makes effective press for opponents.
- From an energy efficiency standpoint LNG’s economics are dubious at best. Huge amounts of energy are needed to cool and maintain the gas in its cryogenic state.

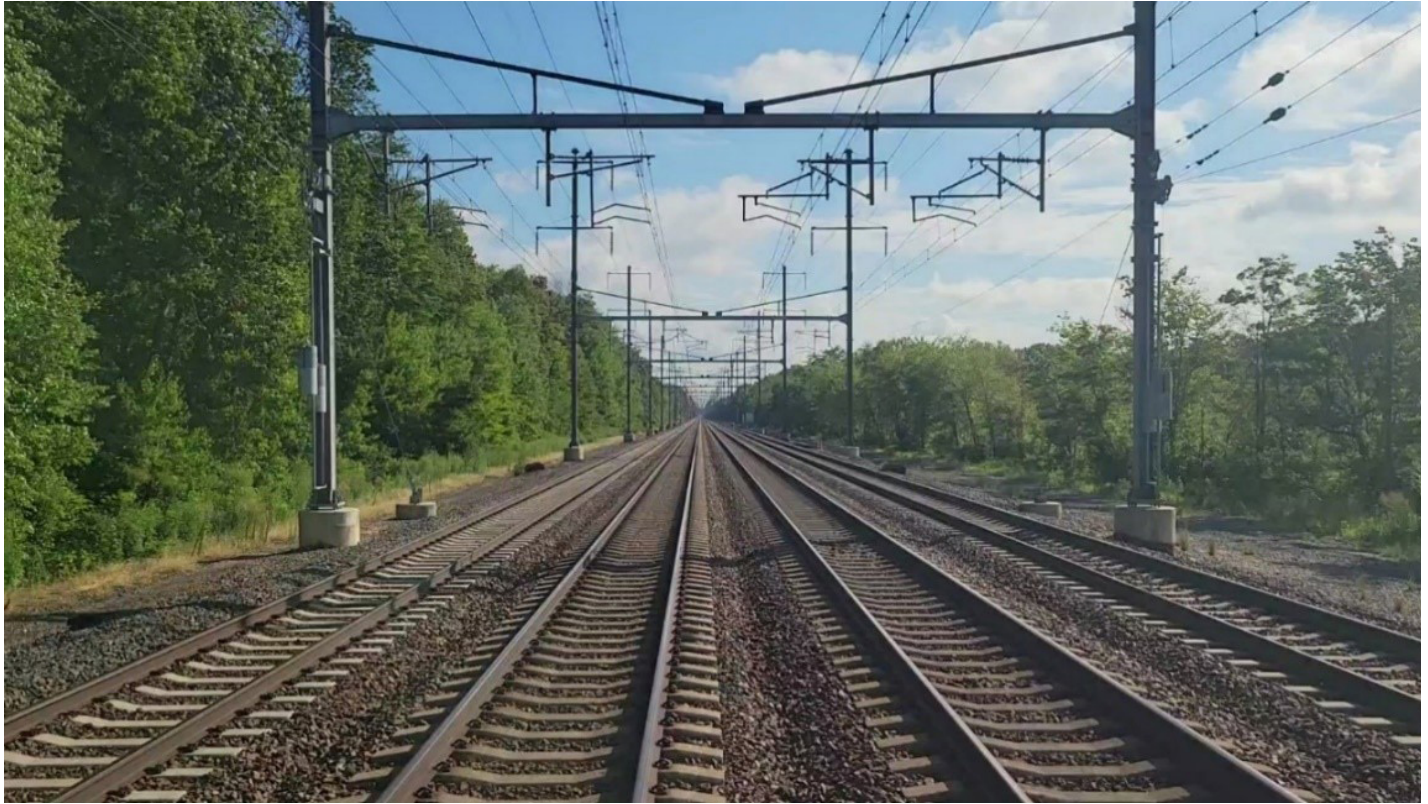

AMTRAK'S 4-TRACK ELECTRIFIED NORTHEAST CORRIDOR MAINLINE IN NEW JERSEY (PHOTO: RAIL SOLUTION, LEWIS FOSTER)

Railroads and Environmental Justice

Railroads and trains have had a complicated past, a promising present, and will have a beneficial future to increase passenger and goods mobility and reduce air pollution, when planned with equity in mind. Construction and expansion of railroads and train services, if operated with responsible land use, with clean zero emissions technologies for passenger and freight rail, will and do provide benefits for public health and climate justice. Environmental justice issues that are centered on race, income, and differing abilities can be overcome through careful planning for, and oversight of, the construction and operations of clean passenger rail and efficient, sustainable freight rail. Providing equitable, affordable access to passenger rail, and preventing inequitable environmental and social impacts of passenger and freight rail, should be central to rail planning and operations. Therefore, public agencies and private rail providers must proactively make environmental, disability, youth, elder, and social justice advocates a part of rail planning and operational decisions.

Impacts on low-income communities from highway construction and from railroad operations are not the same in overall magnitude. Railroads entered urban areas decades ago and housing grew up adjacent to them. In

more recent decades, interstate highways were bulldozed and blasted through urban corridors where the existing housing and businesses were completely eradicated under the banner of “urban renewal” and great numbers of people were displaced. This is not to minimize the local impacts of railroad operations to communities, but highways have a far greater environmental justice impact overall. Rail improvements on existing rights-of-way are not nearly as damaging as freeway construction and expansion. The geographic land footprint of rail corridors is much smaller than the road footprint needed for the equivalent transportation ‘throughput’ capacity.

It is important to compare and contrast the impact in populated areas of a multi-track electrified rail corridor vs. an interstate highway. The above photograph is of the Amtrak Northeast Corridor, the busiest intercity rail passenger corridor in North America. The distance between the catenary supports approximately the width of one-half of a 4-lane Interstate highway. However, the rail corridor has a much greater throughput capacity, less emissions, less noise, and because it has been there a hundred years, does not need to displace people, businesses, and homes bulldozing new right of way through populated areas.

PAST INEQUITIES IN RAILROAD DEVELOPMENT AND OPERATIONS

In the mid-nineteenth century railroads began to be developed as key components of the transportation infrastructure of North America. Yet like most industries of that era, railroad development across the country was tainted by racism and exploitation of indigenous and immigrant communities (especially Chinese and Irish) across the country³².

The development of rail westward across the United States displaced indigenous people. Indeed, the transcontinental railroads began to undercut indigenous independence before any track had even been laid, since all possible routes were required by federal law to be part of a territory or state, and to have clear, unopposed access to a vast amount of land. This was for not only the right-of-way where the rails would run, but the massive land grants given by the government to the railroad companies. This was, of course, impossible without removing indigenous tribes who had lived in that land for generations. This resulted in years of “vigorous effort” to move people out of the way and confine them to reservations. Then the completion of the transcontinental railroads allowed settlement by American and European immigrants of vast sections of the American West and Midwest, further displacing and impoverishing indigenous people³³. In more recent times the development of railroad facilities, such as intermodal terminals, in urban areas has generated a large of amount diesel exhaust pollution, noise and other impacts to adjacent communities.

Despite these past and present inequities, passenger rail and public transportation are inherently more equitable and environmentally sustainable transportation modes than cars and trucks. The wholesale adoption of automobiles and trucks as the dominant transportation mode in North America, the concomitant shift away from rail and public transportation, and the community forms developed over many decades, have caused a number of well-documented negative effects on social equity, public health, and the environment. One of these negative effects of owning a car is the strain on the budgets of low-income families and individuals when they are forced to own and maintain a car in order to carry out the activities of their lives: to shop, commute, go to school. This burden on low-income families of our auto-dependent transportation system and sprawling urban form is a challenge for urban, suburban and rural

32. <https://www.theguardian.com/artanddesign/2019/jul/18/forgotten-by-society-how-chinese-migrants-built-the-transcontinental-railroad>

33. “American Indians and The Transcontinental Railroad,” *American Indians and the Transcontinental Railroad* | AP US History Study Guide from The Gilder Lehrman Institute of American History

families, but while public transportation systems in urban areas have varying levels and quality of service, public transportation in rural areas is uniformly poor, leaving many low-income families effectively stuck, relying on infrequent and poorly funded public transport, or the generosity of friends and family. Similarly, when people age out of driving or can no longer drive to a medical condition, they become prisoners in their own homes if they do not have access to decent transportation.

A restored nationwide system of regional and intercity passenger rail, coordinated with local public transit, would make it more possible for both urban and rural low-income families to access health care, education, jobs, and community life. The same holds true for youth, elders who can no longer drive, and disabled people. Improved passenger rail would improve transportation access and support local economies everywhere from small rural towns to central cities, suburbs and Native American reservations. Many public transit users in North America are people of low and moderate income, people of color, and disabled people, yet the development of modern urban light rail transit systems often has taken place in areas closer to higher-income neighborhoods,³⁴ leaving poorer neighborhoods served only by older, slower bus routes. This quote from the Transportation Equity Network, a coalition of community groups, equitable transportation advocates, civic organizations, and other stakeholders in Chicago, points out the issue and potential solutions:

“Inequitable access to high-quality transportation options has prevented growth and investment in Black and Brown communities and low-income communities. With the persistence of serious racial and economic inequities, along with the election of equity-forward public officials and significant technological changes to our transportation system, there is call for a deliberate and coordinated approach to increase transportation equity and, as a result, improve life outcomes for communities that have historically been marginalized.”

FREIGHT RAIL IMPACTS

The impacts and net benefits to communities alongside freight operations are different from those of passenger rail. Low-income communities across the country in particular are impacted by the freight train routes and freight rail yards which are often located close to or within their communities. The burden of negative impacts of freight railroad operations disproportionately falls upon people of color. These impacts consist of pollution from diesel locomotives, noise pollution

34. <https://nascsp.org/wp-content/uploads/2018/02/issuebrief-benefitsofruralpublictransportation.pdf>

from switching operations, blocking of local streets by increasingly long freight trains, inadequate and outdated rail crossings leading to potentially fatal crashes, and inadequate patrolling and maintenance of rail rights-of-way, impacting neighborhood health and safety³⁵. The number of derailments has declined over the past several decades, but still happen at an alarming rate. The February 2023 derailment in East Palestine, Ohio, and other very recent derailments involving hazardous materials, show the dangers faced by trackside communities. In the aftermath of the Ohio derailment disaster, Rand Corporation researchers Brad Martin and Aaron Clark-Ginsberg described a connection between local environmental justice and a broad, inclusive definition of national security³⁶:

National security is about protecting a nation and its people and their well-being. Which means that certain aspects of infrastructure and services are so fundamental to this effort — fundamental to the very functioning of society — that their continued ability to function is also considered a national security issue.

A secure food supply, for example. Or energy supplies, public safety or protection against environmental threats. Yet last week residents of East Palestine were drinking only bottled water; livestock and fish are dying suddenly; the possible health and environmental outcomes, though they remain unknown, are quite possibly dire.

The rail disaster was not the result of an external attack, and although the specific reasons for the accident are still under investigation, it is no stretch to imagine that it was a slow-moving, internally created disaster of neglected infrastructure, leaner staffing models and watered-down safety requirements — a string of decisions favoring efficiency over safety, all resulting in the routing of hazardous cargo through places where people live. The implications of this disaster will no doubt unfold over decades, with invisible contamination hitting already vulnerable people and environments, and lingering long after the cleanup crews leave.

There is a great need for more stringent safety regulation of railroads, including more resources for FRA inspections and enforcement. Freight rail operators must be accountable to, and communicate with, the communities in which the operations take place.

35. Jocelyn Vivar, *East Yard Communities for Environmental Justice* and Mark Vallianatos, *Urban & Environmental Policy Institute (UEPI)*, Occidental College, written for *The Impact Project*, <http://www.theimpactproject.org>. *Tracking Harm: Health and Environmental Impacts of Railyards*

36. <https://www.latimes.com/opinion/story/2023-02-19/ohio-train-derailment-environmental-threat-infrastructure>

Unfortunately, Federal law has largely shielded railroad companies from accountability to local communities. Public agencies with responsibility for rail oversight, and the freight providers themselves, must proactively reach out and establish relationships with community groups in impacted communities, and prioritize changes in operations that protect the health of the communities.

Local criteria air pollutants from diesel trucks and trains (carbon monoxide, ground-level ozone, lead, nitrogen dioxide, particulate matter, and sulfur dioxide) do move outside the immediate surroundings and can impact surrounding further away from a railyard, and drift elsewhere within a region. Also, even if GHG emissions through more energy efficient transportation (i.e. mode shift to rail) could be lowered, the increase in local criteria air pollution affecting atmospheric chemistry will still affect GHG concentrations and offset some of the benefits of the GHG reduction³⁷. It is imperative both for the health and safety of local communities impacted by freight operations, and for the climate as a whole, that rail operations electrify as quickly as possible, including fully electric rail yard operations.

Finally, though, it should be noted that replacing trucks - even electric trucks - with electric freight trains to move trucks off the road would benefit public health and the environment, so the development or redevelopment of rail-served industrial areas should be encouraged along with rail electrification (with appropriate environmental regulation).

In many parts of the country, pollution from freight movement is a much more significant source of pollution than passenger cars. With the e-commerce boom, truck traffic has exploded in many populated areas in the U.S. already facing heavy pollution. For example, in Southern California's Inland Empire region (consisting of San Bernardino and Riverside counties), the number of daily truck trips has increased from 140,000 to more than 500,000 over the past thirty years. There has been a fourfold increase in diesel trucks, while population merely doubled over the same period³⁸. Electrified freight rail, combined with freight mode shift away from trucks, can reduce polluting diesel truck traffic in residential neighborhoods.

RAILROAD RIGHTS-OF-WAY AND ENVIRONMENTAL JUSTICE

The United States has the most extensive system of railroad rights-of-way in the world. Most are owned by private rail corporations, but—since deregulation in the

37. <https://www.epa.gov/air-research/air-quality-and-climate-change-research>

38. <https://www.latimes.com/california/story/2023-02-05/warehouses-big-rigs-fill-inland-empire-streets>

1970's—the number of miles of rights-of-way owned by the big Class I railroads has declined from 196,479 to 92,282 in 2019—a decline of 104,197 or 53%. In that same period the number of Class II and III railroads has more than doubled, and extends 47,500 miles³⁹. Well over half of the 104,197 miles that are no longer operated by the Class I railroads are not used by the short line railroads either. Some rights-of-way are currently unused though still owned by rail companies or other entities; some are abandoned; and some have been turned into rail-trails.

As a renewed and restored passenger and freight rail system comes into being in North America, unused or under-utilized rail rights-of-way offer many opportunities for establishing a just and equitable transportation system.

In seeking to use an existing right-of-way, potential new passenger rail service providers and/or advocates should emphasize the positive effects of increased rail service on social equity and well-being. A key consideration in advocating for and planning new routes should be how the proposed new project increases (or decreases) accessibility and mobility for people with insufficient access to mobility. The net effect should be to increase mobility.

There are additional considerations in seeking to use an existing right-of-way, as well as in developing rail service on a new right-of-way. It is imperative to avoid the mistakes of the past. In rural areas, rail project proponents must, very early in the planning process, consult with indigenous communities with ancestral and existing claims on the land through which the route will pass. Urban and suburban areas are similar, but with larger and more diverse populations. Early coordination and consultation with affected communities is key to equitable rail development.

The planning of a proposed passenger or freight rail route or service should strive to minimize adverse impact on affected communities, with full consideration of mitigation measures such as electrification. It should also be noted however that a relatively small number of lineside stakeholders have blocked worthy rail projects in existing rail rights-of-way that have enormous environmental and public benefits. For example, a handful of trackside residents in affluent communities have filed lawsuits against construction of electrification infrastructure along a rail corridor merely on aesthetic

grounds. Such unreasonable opposition to infrastructure development harms both the environment and mobility for society at large. To meet the challenge of climate change and many other environmental and societal problems related to transportation, this tension between local and macro priorities needs to be addressed.

UNIVERSAL BASIC MOBILITY

The concept of “Universal Basic Mobility” is a useful lens through which to view the goal of a restored, sustainable and equitable rail transportation system. As described in a recent news article⁴⁰:

“Universal basic mobility is the idea that all citizens should have a decent range of affordable transport options, regardless of their socioeconomic status or disabilities. It’s similar to the idea of universal basic income but focuses on transportation to fight inequalities.”

“Multiple disadvantages, based on socioeconomic circumstances, location and movement impairment, prevent certain people from using transport. Ethnic minorities, students, the elderly and women are all said to be particularly at risk of transport poverty. A growing global movement is proposing universal basic mobility as the solution to democratize transportation. At the heart of this concept lies the belief that a mix of partnerships and policies should provide support to cover travel costs and ensure that everyone can access mobility safely and effectively.”

Policies that could increase universal basic mobility in rail transportation would be:

- Subsidize rail fares for elders and disabled.
- Youth passes for teenagers should be available.
- Reduced or free fares for low-income families who need rail to access basic services like medical, employment, family support accessible transportation to stations, step-free access to trains and stations, signage for visually impaired users.

TRANSPORTATION PLANNING, SOCIAL AND ENVIRONMENTAL EQUITY, AND RAIL ADVOCACY

In recent years some transportation professionals have detailed the ways in which transportation policy in North America favors auto-centric transportation, and the effects of these preferential policies on social and

39. The source for the data on Class I railroads' right-of-way mileage is Table 1-1 of USDOT's National Transportation Statistics 2021, 50th Anniversary Edition.

The source for the data on Class II and III railroads' right-of-way mileage is the American Short Line and Regional Railroad Association's web site at <https://www.aslra.org/advocacy/short-line-overview>

40. <https://www.euronews.com/next/2022/05/20/universal-basic-mobility-cities-tackle-the-transport-gap-with-free-transit-e-bikes-and-car>
<https://thehustle.co/11152021-universal-basic-mobility>

environmental equity. As rail advocates engage in public fora regarding the direction of our transportation policy and proposed new infrastructure, we should use the insights from this research in our arguments for rail as more equitable transportation. Here is a list of some of those preferential policies and their results from “A New Social Equity Agenda For Sustainable Transportation,” by Todd Litman of the Victoria Transport Policy Institute, and by Marc Brenman. Social Justice Consultancy and Senior Policy Advisor to The City Project⁴¹:

“Planning that favors automobile travel is inequitable in several ways:

Non-drivers as a group receive less than their fair share of transport funding which is unfair (horizontally inequitable). For example, in a typical urban area, 10-20% of trips are made by nonmotorized modes yet only 2-5% of total government transportation budgets are devoted to nonmotorized facilities, and an even small portion including private expenditures on parking facilities mandated in local zoning laws.

Wider roads and higher motor vehicle traffic volumes and speeds impose delay, risk, discomfort and pollution on other road users, particularly pedestrians and cyclists.

Since physically, economically and socially disadvantaged people tend to rely heavily on walking, cycling and public transit (or described differently, people who drive less than average tend to be disadvantaged compared with high-annual-mileage motorists), these impacts tend to be regressive (vertically inequitable).

These policies tend to cause automobile-dependency: transport systems and land use patterns which favor automobile access. This provides inferior access for non-drivers, and transport costs on lower-income households (Agrawal 2011).”

Local, county, regional and state transportation agencies typically have a ‘project pipeline’ of many road projects in various stages of development, many of which could have significant environmental justice impacts to communities. While some states and local jurisdictions have enacted transportation planning policies more responsive to the environmental and community impacts, many projects in the “pipeline” were proposed before such policy changes. Thus, many projects in the pipeline for funding are not consistent with current climate, equity and public health policies, and should be re-evaluated⁴².

41. <https://www.vtppi.org/equityagenda.pdf>

42. <https://cal.streetsblog.org/2022/07/07/transportation-projects-in-the-pipeline-must-be-reevaluated>

Freight Rail

Traditionally, dedicated government agencies concentrate on each mode's infrastructure separately. Highway agencies build and maintain roads. The Army Corps of Engineers builds and maintains waterways. Airport authorities build, maintain and operate airports, with the Federal Aviation Administration provides air traffic control, radar and other services which allow private airlines to operate. Freight railroads primarily rely on private infrastructure with little government funds available for facility investments. This lack of government support often puts rail, the most energy-efficient mode, at a financial disadvantage to the highway, air, and water modes.

According to the Bureau of Transportation Statistics, in 2019 railroads handled 30% of the ton-miles of freight in the U.S. while trucks moved 44%⁴³. However, measured by freight dollar value, rail handled less than 4% in 2017, and truck 71%⁴⁴. Medium and heavy-duty trucks produced 26% of greenhouse gas (GHG) emissions from the U.S. transportation sector in 2020, while rail produced just 2%⁴⁵. The far lower emissions of rail (compared to truck), are due to the inherent energy efficiency of rail transportation. To reduce GHG emissions, as well as the six 'criteria pollutants' (carbon monoxide, ground-level ozone, lead, nitrogen dioxide, particulate matter, and sulfur dioxide), and to reduce road congestion, crashes and costly damage to road surface, more freight movement in the U.S. needs to be shifted from road to the rail mode.

The chair of the Surface Transportation Board (STB), Martin Oberman, clearly understands how important trains are for mitigating the climate crisis. As he described in a September 2021 speech to the North American Rail Shippers Association convention⁴⁶:

"The strategies pursued by the railroad industries as a whole, and it is not the same among all the Class 1s, have serious implications as to whether the 'common carrier mandate' is being carried out as intended and as required by statute. This is a subject that may warrant further exploration by the STB."

According to the Federal Register: "The 'common carrier' obligation refers to the statutory duty of railroads to provide "transportation or service on reasonable request." 49 U.S.C. 11101(a). A railroad may

not refuse to provide service merely because to do so would be inconvenient or unprofitable."

Historically, Oberman said, "Congress recognized ... that the railroads ... can restrict supply and raise prices. To avoid this outcome, the United States decided long ago that the public interest requires some balance between the railroads operating as private profit-making companies ... and the public's interest. This is true because many railroads in various parts of the country have a natural concentration of market power."

We know that for every one percent of freight lost by the railroads to trucks it amounts to an extra 5 million tons of CO₂ dumped into the atmosphere. Yet, since 2002, railroads have lost nearly 2% of freight market share to trucks. Again, this is not counting coal ... If railroads had just kept the same share of market, they had in 2002 there would be one million fewer trucks on the highways each year..."

The result: "That means an extra 8.2 million tons of CO₂ pumped into the atmosphere annually from this lost growth... Since 2002, over 123 million tons of global warming CO₂ has been pumped into our atmosphere just because the railroads chose not to maintain their market share as compared to trucks."

Government at all levels must take an intermodal approach to transportation policies to assure that public and private investments are made in a manner to encourage traffic to move via the safest, most energy efficient, least polluting, if not most cost-effective mode. Trucks will always have a vital role in transportation, as at least a short truck haul will still be required at the beginning and end of most trips ("first-mile, last-mile"). The road network will always be far more expansive than the rail network. However, a huge portion of the ton-miles currently moved by truck could feasibly, and should, be shifted to more environmentally-friendly rail.

The Infrastructure Investment and Jobs Act (IIJA, Section 21101) creates a new Office of Multimodal Freight and Infrastructure Policy at the USDOT. This new office has great potential to advance and support rail-truck intermodal freight transport. Some most important cases involving rail (setting very important precedents) brought before the Surface Transportation Board are going to be decided in the next couple of years. They have huge environmental implications, especially for greenhouse gas emissions, largely due to implications for the mode share of rail vs. road transportation in the U.S.

43. <https://www.bts.gov/content/us-ton-miles-freight>

44. <https://www.bts.gov/topics/freight-transportation/freight-shipments-mode>

45. <https://www.epa.gov/greenvehicles/fast-facts-transportation-greenhouse-gas-emissions>

46. <https://ajot.com/insights/full/ai-stbs-oberman-says-u.s-railroads-reduced-service-raised-rates-and-derived-191-billion-in-dividends-and-buybacks-since-2010>



HUPAC INTERMODAL “ROLLING HIGHWAY” TRUCK-ON-TRAIN TERMINAL IN FRIEBURG, GERMANY (PHOTO: RAIL SOLUTION, DAVID FOSTER)

About 90% of all dry van and refrigerated truckloads moving in the U.S. never use rail on any part of their journey. The freight mode share of rail has huge potential to increase in the U.S., especially if railroads offer faster, more reliable and cheaper short- and medium-haul freight rail service.

Freight “logistics sprawl” is the building of warehouses, distribution centers and other freight facilities on cheap land in rural areas or suburban/exurban fringes of metropolitan areas only accessible by road, and a long distance from urban centers. This logistics sprawl is a major driver of increased truck vehicle miles traveled (VMT) in the U.S. Rail-oriented freight development, similar to rail or transit-oriented residential development, needs to be studied by the DOT to develop a strategy for encouraging freight rail as an alternative to truck drayage between the nation’s ports and inland destinations. With frequent short- and medium-haul freight rail shuttle trains, much of this freight presently moved exclusively by highway could be shifted to rail, to reduce highway congestion and pollution.

The overall annual tons of coal shipped by U.S. railroads declined from nearly 900 million tons in 2008 to 400 million tons in 2021 (though it still represents 27% of overall railroad tonnage and 11% of railroad revenues)⁴⁷. The number of annual MWh of coal-generated electricity in the U.S. has dropped by half over the same period as a result in reduction in coal mining. The rail system capacity thus freed up by fewer coal trains provides an

opportunity for U.S. railroads to expand into new areas of freight business that are now dominated by truck. The reduction in business from fewer coal and oil shipments could be more than made up by new business lines that railroads could get if they made an effort to do so.

ROLL-ON, ROLL-OFF/ NEW FORMS OF INTERMODAL FREIGHT TRANSPORT

Containerization of freight is a popular and energy-efficient technology for long-haul movements via water, highway, and rail. However, the high costs involved in building and operating conventional intermodal container terminals has traditionally discouraged its use for ‘short-haul’ rail movements under 500 miles. For short-haul moves, new European rapid-load/unload ‘roll-on/roll-off’ intermodal technologies use terminals that are simple and low cost.

To maximize the energy and environmental advantages of rail by moving much over-the-road freight to rail, ways must be found to make significant inroads into the truck traffic that conventional rail intermodal does not yet capture.

Double-stack rail intermodal has been very successful for the railroads and has handled large volumes of containerized freight that would otherwise move on highways. However, the concept is mature and physical limitations hamper its growth. Containers and certain trailers are marshalled in vast terminals requiring hundreds of acres and large overhead cranes. Drayage costs associated with moving containers into and out of

47. <https://www.aar.org/wp-content/uploads/2020/07/AAR-Coal-Fact-Sheet.pdf>

these terminals limit the competitive geographic radius that can be served.

A less capital intensive and nimble intermodal concept is needed to continue rail intermodal growth and to handle all kinds of truck trailers, not just specially equipped dry vans. In Europe companies such as Hupac, RAlpin, and Ökombi operate such trains carrying entire trucks on flatcars and the drivers in sleeping cars. This truck-on-train concept is known in Europe as “rolling highway” or “land ferry”, and governments encourage these trains as a means of reducing large truck traffic on highways.

In the United States this concept has not yet been tried, but the truck ferry idea holds the promise of further reducing trucks on the road. Here are some of the advantages:

- Enhanced productivity for drivers. The truck continues its journey while the driver sleeps instead of sitting parked at a roadside rest area or truck stop.
- Extend rail intermodal market into currently underserved markets of less than 1,000 miles, creating new business for railroads.
- Truckers and railroads are allies, not competitors. Trucks keep all their existing business but become customers of the railroad for a line haul move.
- Fewer truck miles driven on the highway means reduced emissions, crashes, highway maintenance, and congestion

RAIL FOR “LIGHT FREIGHT”: MAIL AND SMALLER PACKAGE HANDLING

Electric trucks and delivery vans are appropriate for short distances; but long-distance mail and lightweight parcel package haulage should return to the railroads, either in intermodal freight trains or in mail storage cars or baggage cars of passenger trains. Even regional or commuter trains can be used to move mail to/from suburbs with combination coach-baggage cars that were once common on suburban trains of all kinds.

The specialized geography of mail and/or package handling differs from the rest of the trucking industry. The organizations involved include U.S. Post Office, United Parcel Service, Federal Express, DHL, and perhaps many smaller firms. An important part of mail, parcel and package handling is ultimate delivery to homes and small businesses.

A century ago, and indeed close to the beginning of the Amtrak era, mail and express were important revenue factors in the operation of passenger trains. They likewise kept many of the interurbans on the thin edge

of profitability. Back then the Railway Express Agency covered most of the conventional railroad network, and may have contributed to interurban package freight business because of its ability to ‘interline’ package shipment. The Railway Express Agency operated a nationwide fleet of green trucks for local delivery, and were as common on U.S. streets as Amazon, FedEx and UPS delivery vehicles are today. Conversely, the United States Postal Service (USPS) was understood as primarily a carrier of personal correspondence and business mail, although advertising and catalogs must have been rather important even then.

The rise of e-commerce has led to the creation of giant package handling plants for both USPS and the private carriers, almost always located away from rail lines. Thus, it may be that the only way that ‘mail and express’ can return to railroads is through intermodal shipment of the long-distance portion of the trip, with trucking confined to the ‘last mile’ between the intermodal yard and initial/final end points for a given shipment.

Class I rail corporations’ monopolistic practices skew freight away from rail, and governments’ general-fund spending for highways skews everything towards trucking

The trucking industry is heavily subsidized. Highways are built and maintained with public funds, while rail corridors are mainly privately owned and maintained. To accommodate the large truck traffic, highways need to be constructed with thicker and stronger pavement to bear the weight of heavy trucks. And the continuous heavy truck traffic causes the overwhelming amount of the damage to roads; yet truckers pay only a small portion of the cost of highway construction or maintenance through gasoline excise taxes. In addition, highways are furnished with additional lanes, runaway ramps, and truck parking areas needed only for trucks. These large subsidies should attract increased public scrutiny because they give trucking an advantage that leads to increased GHG and other pollution from transport. Electric trucks carrying the same loads as existing diesel trucks will have significant limitations in range for the foreseeable future, and will cause even more road damage since with batteries their gross weight will be even higher.

With these large public subsidies, over-the-road trucking is not on a level playing field with freight rail (which is privately owned and financed, with little or no subsidy). Federal and state highway budgets have historically been an order of magnitude greater than the amount allocated to rail. New higher truck fees and increased fuel taxes, and perhaps toll charges for trucks, are needed so that trucks pay for the entire cost of repairing the damage

they do to highways and the significant extra cost they impose on building or re-building highways.

Since more freight is moved by trucks than by rail, the hidden costs of highway freight are substantial. At the federal level, since gas and diesel excise taxes are not tied to inflation and haven't increased since 1993, federal gas taxes only fund about half of total Federal highway expenditures. The rest comes from the General Fund. When transport rates are artificially low, more freight is shipped longer distances. The price of fossil fuels for transportation will undoubtedly rise. The longer governments take to switch out of their highway-centric thinking, the more difficult and disruptive for our economy it will be to implement and adjust to new policies necessary to reduce carbon emissions.

Road transportation has received extensive government subsidies for the past century, giving it an unfair advantage over rail transportation. Truckers don't have to own the roads, but railroads do own their own tracks. Trucks only pay property taxes on their terminal facilities since the roadway network is publicly owned. Railroads have the added cost of property taxes on their rights of way, which burdens their economic model and discourages capacity-boosting investments such as double tracking, railyard sidings, and electrification.

Highway freight transport prices in the United States are artificially low because of subsidies and the exclusion of external costs – costs generated by freight transportation services we consume that are borne by others. Examples of external costs include crashes (fatalities, injuries, and property damage); emissions (air pollution and greenhouse gases); noise; military costs associated with protecting America's supply of imported oil; and unrecovered costs associated with the provision, operation, and maintenance of public facilities such as roads, bridges and airports³. The external costs are also felt by truck drivers, many of them work for subsistence wages. They often must live in the truck for long periods of time, far from home. The industry seduces many young people into the idea that by signing on and become an independent driver, they will be entrepreneurs. The truth is that too many become underpaid in highly exploitative working conditions.

RAILROADS AS A BUSINESS

Class I railroads are defined by the U.S. DOT as having annual revenues in excess of over \$900 million. The seven Class I railroads in North America are BNSF, Union Pacific, CSX, Norfolk Southern, Canadian National, Kansas City Southern-Canadian Pacific (recently merged), and Ferromex. In addition, the national

passenger railroads in the U.S. and Canada —Amtrak and Via Rail— would both qualify as Class I if they were freight carriers. Class I railroads haul the great majority of U.S. rail freight ton-miles, with the rest hauled by hundreds of smaller Class II and Class III railroad companies.

Railroads are capital-intensive businesses. They require huge value in physical assets such as land, track and signal systems, bridges, locomotives, and cars. As corporations, railroad companies have the fiduciary requirement to make the maximum possible value for their stockholders. That means, simply, maximize revenue and minimize expenses. Sure, they must comply with the Federal Railroad Administration regulations of the business they conduct, including safety rules and practices. They must comply with regulations about accounting and reporting. They are generally guided by their chartered purpose. The main requirement, however, is to make as much profit as possible. This means keeping operating expenses as low as possible while simultaneously keeping rates as high as can be gotten away with. This approach most certainly does *not* place an emphasis on making new capital investments that require more than a few quarters to pay off. It also leads to employee burnout and excessive staff turnover.

US railroad companies generally have geographic areas in which they have a monopoly in rail transportation. The pricing power of this monopolistic position gives each of the seven Class I rail companies across the country abnormally high returns. The environmental issue is that these rail companies could carry a significant amount of the freight currently being carried by long-haul trucking; the economic issue is that they could do this profitably—just with not so high a percentage rate of return.

Freight customers have limited choice in rail carriers, if they have any choice at all. Labor is placed in the same position. Railroad operations positions require job skills that do not easily transfer to other industries. Rail employees thus may have no choice but to accept the working conditions their employers give them.

The railroad industry is vertically integrated: that is, one company owns both the tracks and the trains that run on them. There are a few instances that involve a railroad being required to give another of the major railroads access to its tracks as a merger requirement. For example, BNSF Railway was given the right to use Union Pacific tracks in several areas as a condition of Union Pacific's merger with Southern Pacific. As long as trucks are considered to be competition, railroads are pretty much free to charge transportation fees or provide a level

of service that is unacceptable for any shipment that they deem insufficiently profitable or too much work to be worthwhile. If shippers don't like the terms, they can always ship by truck or barge.

As corporations, railroad companies have the fiduciary responsibility to act in the best interests of the stockholders. That is accepted to mean making the greatest possible amount of profit. There is no meaningful requirement to consider the public interest in their business practices. The industry is currently using the term Precision Scheduled Railroading (PSR) to represent that effort. PSR is a way to minimize the cost of traffic that the industry wants and to discourage traffic that it doesn't want. Competition from cars, trucks, barge and airplanes led to severe declines in rail passengers and freight shipments after World War 2. These competing modes of transportation were also receiving vastly greater amounts of public subsidy. Prime examples of public subsidies include the building of the Interstate Highways, construction of airports, and the Federal Aviation Administration's modern air traffic control and radar systems.

By the end of the 1960s, U.S. railroads had been pushed into a severe financial crisis. A particularly hard blow to the railroads was the loss of express freight (parcel) and U.S. Postal Service shipments in 1967, which shifted to trucks and airplanes. The Penn Central Transportation Company was formed by the merger of three major northeastern railroads (the Pennsylvania, New York Central, and New Haven) between 1968 and 1969 in an attempt at survival. However, the combined company soon went bankrupt in 1970. At the time, this was the largest corporate bankruptcy in U.S. history. The collapse of the Penn Central led the U.S. Congress to take action to restructure the railroad industry and save it from financial ruin. In October 1970, President Richard Nixon signed into law the Rail Passenger Service Act. The legislation enabled railroads that operated (mostly unprofitable) intercity passenger-rail lines to turn the service over to the new National Railroad Passenger Corporation, allowing them to focus on freight business. The new federal passenger railroad, under the brand name Amtrak, launched service on May 1, 1971.

Despite being relieved of the financial burden of providing passenger service, major U.S. freight railroads continued to go bankrupt through the decade of the 1970s. Federal railroad bailouts from acts of Congress in 1973 and 1976 led to the more comprehensive Staggers Rail Act of 1980. This legislation largely established the business model of the U.S. rail industry as we know it today. It removed most economic regulation from the railroads,

on shipping rates and operations. This deregulation encouraged mergers and consolidation of the freight railroads, and freed them to focus on the most profitable lines of business: long haul, bulk shipments. The overall mileage of the U.S. railroad network also steadily shrank after the passage of the Staggers Act, as less-used lines were put out of service.

Under current transportation policy, banks and stockholders are determining what transportation is available, and ultimately, what environmental impact our transportation has. The large Class I railroads and their investor owners prioritize maximizing short-term profit, at great societal impact and harm to their own customers. Lack of reliable freight rail service adds to the environmental and road damage problem of more freight being shifted to trucks on the highway. Railroad customers are fed up with late shipments, poor service, and even being denied service, etc. Many customers face hefty and unfair penalties for failure to meet railroad carrier 'schedules', even though the railroads regularly deliver shipments days late to the same customers.

Railroads, owning and utterly tied to their infrastructure, are among the most capital-intensive industries. Manufacturing companies own a facility here and there, a few hundred or a few thousand acres and some buildings. Extractive industries can buy properties, strip them of resources, and resell them. Airlines own airplanes and maybe a little ancillary property. Truck companies own some trucks and maybe some ancillary property, but many truck companies rely on contracting rather than owning trucks. Bus companies are in a position similar to trucking. Taxi and similar companies may own some vehicles and property, but the trend is increasingly a contract arrangement, such as used by the ride sharing companies that own only software. They all use government-funded transportation infrastructure. The use of the infrastructure is generally subsidized. The payment for using the infrastructure is less than the cost of owning and maintaining the infrastructure, whether it be airports, navigable waterways, or roads. Railroad companies, with very few exceptions, own the property the tracks and other facilities occupy. They construct and maintain their tracks, stations, yards, and maintenance buildings. They often pay state taxes on the property they own. They are expected to bear all of the capital expenditure and expense, yet survive in a business environment among subsidized competition.

In the past, investors valued longevity and stability in their investments, and railroads could fit that description. This made the need for capital investment more acceptable than it is now. But the railroads of

today have to deal with the investor sentiment of today, which focuses on quarterly earnings reports rather than long-term outlook. So, railroads now are motivated to eliminate as many assets as they can while still remaining in business. They may abandon or sell low-revenue branch lines. They have closed yards, terminals, and maintenance facilities. They sell off locomotives and cars. Two-mile-long “monster trains”, while minimizing operating costs, greatly slow and congest the network while increasing the severity of derailments⁴⁸. For example, since passing sidings are too short to accommodate these longer trains, traffic is slowed as trains are unable to pass each other over long intervals of track. Longer trains cause more inconvenience to the general public at crossings. All of this cheese-paring requires that railroads be selective about what traffic and terms they will accept. Transportation charges are based on weight and distance, a fee structure that makes lightweight freight undesirable.

US freight rail service generally has poor reliability and poor on-time performance, largely a result of cost-cutting and downsizing. Consequently, Class I railroads are subject to almost continual complaints about poor service from their own customers. The management culture of the deregulated U.S. freight rail industry over the past four decades, formulated during times of economic distress in the rail industry during the 1970s and 80s, has resulted in cutting jobs, cutting corners on safety, price gouging of shippers, less maintenance, abandonment of lines and customers, lower capital spending, closing facilities, idling equipment, etc. Continued slowing down of freight, ever-worse customer service, abandoning infrastructure, has led to a vicious cycle of destroying the long-term viability of freight railroads⁴⁹. This is all happening while the Class I railroad companies themselves are enjoying record quarterly profits. Under a different incentive structure, much of the revenue which now goes to stock buybacks, could have instead been reinvested in improving and maintaining physical assets of the railroads, as well as hiring and training more crews, and purchasing more rolling stock. These trends have gotten demonstrably worse in the past several years with the advent of Wall Street-driven strategies such as PSR. It is thus not surprising that the percentage of freight mode share of railroads in the U.S. has steadily been declining. The mode share, and overall ton-mile volumes, of railroads in U.S. freight transportation did grow between the passage of the Staggers Act in 1980 and the all-time peak of rail

shipments in 2006. However, Rail freight volumes have been shrinking ever since, even though the U.S. economy overall has grown by about 25% since 2006.

According to the Federal Register: “The ‘common carrier’ obligation refers to the statutory duty of railroads to provide ‘transportation or service on reasonable request’ ” (49 U.S.C. 11101(a)). Under this statute, a railroad may not refuse to provide service merely because to do so would be inconvenient or unprofitable. The common-carrier obligations of freight railroads, to provide freight service to all customers in all markets, need to be strictly enforced by the STB. Some rail freight shipments need to be classified as ‘public service obligations’. Railroads get around this obligation, not by refusing to provide service, but by structuring the service for undesired shipments in a way that discourages these ‘undesirable’ potential customers and makes truck their only reasonable choice. The STB should not interpret common carrier obligations in a way that allows the use of this loophole.

On railroad issues, leadership of the Federal government is essential because states and local governments own a very small percentage of the nation’s railroad tracks and have limited influence and jurisdiction over private interstate railroad companies. Even the paying customers of the Class I railroads have little influence over their operations and business decisions.

Rail transportation is underutilized in the U.S. because of over a century of misguided Federal transportation policy that allows service to be provided on the basis of maximum profit rather than transportation need. Rail freight transportation is generally limited to shipments that are not speed or time sensitive and are not easily shipped by truck. After peaking in 2006, U.S. rail freight market share and relevance has been falling due to the short-sightedness of both public transportation policy and railroad company profit motives/cost cutting. Rail infrastructure needs investment, not downsizing or abandonment, U.S. railroads have been doing for decades.

US railroad companies are subject to Wall Street’s emphasis on short term profit and act accordingly. The stock price can plunge if an analyst publishes a negative report. For example, in the late 1990s, the newly merged Burlington Northern Santa Fe (BNSF) Railway undertook an extensive capacity improvement project. The improvements were overdue and solved problems associated with handling the existing traffic. They were not an attempt to predict future growth. Nonetheless, Wall Street investors criticized the company for what

48. <https://www.propublica.org/article/train-derailment-long-trains>

49. Rail Customer Coalition: <https://www.freightrailreform.com>

they claimed was excessive capital spending.

BNSF was considered the lone exception to railroad companies being subject to Wall Street's short-term emphasis. Berkshire Hathaway purchased Burlington Northern Santa Fe (BNSF) Railway in 2009. Berkshire Hathaway is known for promoting long term growth, not quarterly reports. However, BNSF in recent years has nonetheless adopted PSR-like cost-cutting practices.

For improved and economical operation, railroad companies typically need more capital improvement than they can afford. As capital projects work their way through the budgeting process, they must typically demonstrate a return on invested capital (pay for themselves) in five years or less. The arguments against an improvement that passes that test generally revolve around the question of what happens if traffic declines. There is always the fear of being overbuilt...in the eyes of Wall Street.

In North America there now is the financial/political bias against any kind of capital expenditure by private railroad companies that does not have a return-on-investment payback period of five years or less. This has hampered development of not only electrification but also increased track capacity, new freight terminals that would increase market share, etc. This is an arbitrarily imposed business situation, largely by Wall Street, that needs to be addressed on the Federal policy level. Outside of North America, most of rest of the world's railroad tracks are publicly owned for the most part, so there is less impediment to longer-payback capital investments like electrification that are ultimately better for the railroad and society.

ARE RAILROADS A PUBLIC UTILITY, OR SHOULD THEY BE?

Railroad companies are effectively standing with a foot in each of two buckets. One foot is in the 'business for profit that could just as well be a factory' bucket. The other is in the public utility bucket. Rail transportation and the companies that provide it are simultaneously considered essential and not. If we look at railroad companies as the typical 'business for profit that could just as well be a factory,' their business practices are acceptable, and quite ordinary. However, as transportation companies, they have the right of Eminent Domain and are allowed some monopoly practices. This is the result of the government striving to save railroad corporations instead of rail transportation. When the railroad companies are not acting in the public interest, they usually are not violating their charters or breaking the law.

The STB makes an annual assessment of the Revenue Adequacy of the major railroads. Revenue Adequacy occurs when return-on-investment (ROI) exceeds the cost of capital. Existing with a foot in each bucket, the surviving railroads finally reached revenue adequacy in 2019. The railroad industry is finally financially solvent. This may be reassuring to its corporate executives and investors, but it doesn't run enough trains to make a difference to the US's overall fuel use, or the climate crisis. To change rail transportation, the system that provides rail transportation must change.

WORKING WITH THE RAILROAD SYSTEM WE HAVE

The railroad companies determine what freight they will accept and on what terms, society's need for better rail transportation notwithstanding. Specific improvements to freight service for the public benefit are generally of secondary concern, at best. The railroad companies also dictate the nature and amount of passenger service that is offered to the public. Existing passenger service is often subjected to extensive delays, regardless of legal requirements to the contrary. New passenger service might be instituted, but only after long and difficult negotiations. The railroad companies fear that new passenger service would raise the public's expectation for more passenger service, even if no new infrastructure investment was necessary at the outset. They do not want their currently profitable business model of sparse, slow, high-dollar-amount long distance freight trains to change. From the railroad company perspective, passenger trains, possibly increasing in number as the public comes to expect them, are low profit. Even at low or no expense to the company owning the tracks, new passenger trains are often resisted by the freight railroad.

While railroad companies will reluctantly allow some use of their infrastructure for very limited passenger service, they will not let another carrier use their tracks for freight, unless they are required by the STB to share a track (usually the legacy of a prior merger). This is even if the other carrier's freight is something the host company does not want to carry itself (too little tonnage, too short-distance). For the companies owning the track, it is a matter of principle. For example, Amtrak operated a mail and express service from 1986 until 2004. Regular Amtrak passenger trains had special freight boxcars made for high speed, and special semi trailers that were equipped with railroad wheels. The service was popular, but because of operating agreements with the railroad companies, the cars could only be part of

Amtrak's existing passenger trains. Trains became very long, and delays were extensive. The railroad companies claimed that Amtrak was unfairly taking their business, even though they could not or did not want to provide equivalent service.

Large railroad companies have sold many of their undesired branch lines to small shortline railroad companies, then subsequently refused to let the shortline deliver and pick up freight at their major terminals. They insist that the exchange be made at the remote point where the former branch line connected with the main line. This arrangement places a limit on the service the shortline railroad gives its customers and often delays shipments. Even publicly supported passenger service is subject to decisions based on the (limited) bottom line. The value of the service is measured in revenue (from tickets, incidental sales such as food, and fees such as excess baggage) and direct cost of construction and operation. The decision of whether the service is feasible has been traditionally evaluated by comparing cost to revenue without considering the external benefits (such as climate/environment, safety, and road maintenance).

RAILROAD LABOR

U.S. railroad companies have relatively low employee staffing needs. Two employees can do the work of 200 truck drivers. Since it is difficult for railroads to eliminate their capital needs, they try to eliminate jobs. Part of that effort is to reduce the number of people working on the trains. That has been generally reduced to two. Railroad owners would like that to be one, or preferably none. Automation is widespread throughout the industry. Class I railroad cost-cutting increases safety risks to rail workers and the public. The Federal Railroad Administration (FRA) must aggressively enforce safety rules, and investigate railroad practices which put rail workers and the public at real and unacceptable risk.

In 1970 there were 617,000 railroad employees. A typical train crew consisted of four people (conductor, engineer, and two brakemen). Most moderate to large size cities and towns had at least a freight agent to handle transactions with local businesses. Many of these stations had additional people to attend to passengers and for local management of train traffic. In 2021 dollars, railroad industry revenue in 1970 was \$131,784 per employee.

In 2014 (the most recent compiled data available), there were 235,000 railroad employees. A typical train crew was two people (conductor and engineer), there were no agents for passenger or freight business (by then,

conducted by a small group of people at headquarters, by computer or telephone), and no local traffic control offices (consolidated into headquarters positions, each person doing the work of several people who had formerly worked in several stations along the line). In 2021 dollars, railroad industry revenue was \$367,027 per employee.

Class I railroads have laid off tens of thousands of workers in the past few years alone. According to STB data, about 45,000 railroad workers were laid off between 2016 and 2022, representing 29% of the rail workforce. The workers left behind are being stretched to the limit. Crew fatigue presents a tremendous safety risk to U.S. rail operations, as does insufficient time given to crews doing safety inspections on equipment and track. These staffing reductions also affect reliability and congestion in terminal areas because trains are not ready when the crew comes on duty. Often, the crew that is called to handle the train on the road must first perform switching to get the train ready. The skills lost by letting go so many experienced employees will be hard to get back. Rail transportation skills are not generally directly transferable to other workplaces nor for commensurate compensation. Many railroad employment locations are substantially served by only one railroad. The railroad industry takes advantage of employees by subjecting them to oppressive working conditions, with the knowledge that employees have limited chance for other similarly compensated employment near where they live. Thus a state of monopoly contributes to a hostile labor environment. More railroad education and training programs are needed, as American freight railroads have lost the institutional knowledge needed to handle heavy traffic reliably.

Cuts to railroad maintenance budgets have led to damaged infrastructure, hurting the safety and performance of the whole system. In addition to eroding service quality of freight rail, the workforce reductions of Class I railroads also hurt passenger rail. Fewer railroad maintenance and operations staff on the freight side means more delays for passenger rail, and the greater possibility of passenger trains getting into crashes. There are also fewer railroad company engineering and operations staff to collaborate with public agencies on infrastructure projects which benefit both passenger and freight rail. As described by FreightWaves writer Rachel Premak in a July 14, 2022 piece titled "America's freight railroads are incredibly chaotic right now"⁵⁰:

50. <https://www.freightwaves.com/news/americas-freight-railroads-are-incredibly-chaotic-right-now>

“They’ve cut labor below the bone, really,” STB Chairman Marty Oberman told the House Transportation Committee in May [2022]. “In order to make up for the shortage of labor, they are overworking and abusing the workforces they have.”

The legacies of PSR [“Precision Scheduled Railroading”] have contributed to low employee numbers at the railroads today, said Todd Tranausky, vice president of rail and intermodal at forecasting firm FTR Transportation Intelligence.

[Jason] Doering of Union Pacific noted another trend: super-long freight trains. This is a problem so grave that the federal government literally released a report on it in 2019, saying the trains had gotten so massive that pedestrians were climbing over them and emergency responders were unable to respond to incidents. However, long freight trains allowed railroaders to extract more profit from their equipment and workers, helping reach economies of scale.

...when it comes to railroad conductors and engineers, they really don’t like the mega-trains. One reason is that they’re simply slow, stretching the workdays longer and longer and grinding on morale. “When you’re going up a 20-mile hill going 9 or 10 miles an hour in the middle of the night, it gets on you,” Doering said.

Another reason is that it takes longer to fix them should a car or locomotive fail. Walking along miles of railcars, checking for broken knuckles or stuck brakes at each, isn’t my personal idea of a good time.

“That’s part of the lifestyle issue [in hiring],” Tranausky said. “How many people, when it’s 105 degrees outside or there’s a foot of snow, actually want to trudge a mile, two miles to find an issue, fix that issue, then go back down the road? There’s that lifestyle issue that’s exacerbated for how long the train is.”

COVID wiped out even more railroad payrolls

...Railroads were shedding employees from April until July 2020, when my colleague Joanna Marsh reported that crew headcount had finally begun to increase again. Still, there were 25% fewer crews than in 2019 and 28% fewer than 2018, according to data from the Surface Transportation Board.

The financial status of these firms was in question, which motivated them to furlough workers. “At least one Class I railroad held meetings to decide whether they had enough cash through the summer, if they had enough cash to pay the bills and could they stay in business,” Hatch said. “When they began to lay people off, much to the consternation today of the regulators

and whatnot, you need some understanding that they did not know how long this would last.”

...Railroaders struggled to re-hire those crews they furloughed. Many of them found work in construction or manufacturing, industries that allow workers to spend evenings and weekends at home, Tranausky said.

...these railroads cut too much staff through the adoption of PSR and the pandemic. Rail employment today is down more than 20% since the beginning of 2019, according to the Bureau of Labor Statistics — a “dramatic decline,” Tranausky said.

“It’s possible that the railroads furloughed too many and that they could have taken on more costs,” Hatch said. “I think one lesson out of this in the so-called just-in-case economy of the future will include railroads who will keep more safety stock [of labor].”

PSR helped railroaders boost margins and share prices, but its legacies could be contributing to today’s woes.

To address low staff, Berkshire Hathaway’s BNSF took one particularly unpopular approach. In February [2022], BNSF began to penalize employees who took time off for fatigue, family emergencies or illness. Union officials said 700 rail crew left as a result of the policy. The \$23.3 billion railroader nixed the policy in June.

In December 2022, a national railroad strike was narrowly averted by Congress, which passed a bill (signed into law by President Biden on December 2, 2022) making a national railroad strike illegal. Congress intervened as the threat of a strike loomed, but did not approve the provisions for seven paid sick days leave that workers sought. Under the Railway Labor Act of 1926, railroad workers are uniquely constrained by Congress to prevent strike action. The seven paid sick days which rail workers were asking for in the contract negotiations would amount to a tiny percentage of the profits made by the Class I railroads in the prior year. The lack of sick days in the approved labor contract was predicted by some industry analysts to result in more rail workers quitting in 2023⁵¹. There were also some news reports in early 2023 that Class I railroads were weighing offering more paid sick days along with more flexible work schedules, to retain employees⁵².

Railroad labor must be seen in the context of the climate emergency. Fewer railroad workers means that fewer trains can be run— meaning more freight on more carbon-intensive trucks.

51. <https://thehill.com/business-a-lobbying/business-lobbying/3762605-no-paid-sick-leave-could-spur-rail-worker-exodus-that-ripples-across-economy>

52. <https://www.bloomberg.com/news/articles/2023-01-23/railroads-pay-out-for-worker-benefits-after-years-of-strains>

Passenger Rail

US passenger rail service has three segments: the Amtrak national network, the Amtrak-operated state-supported trains, and regional/commuter service. The Amtrak National Network has two distinct segments, the Northeast Corridor (NEC) and the Long Distance service. NEC is the route between Washington, DC and Boston, plus the lines between New Haven, Connecticut and Springfield, Massachusetts, and between Philadelphia and Harrisburg, Pennsylvania. The rest of the national network, for routes of greater than 750 miles, is called Long Distance service, and sometimes also referred to as inter-regional or interstate Amtrak service. Amtrak is a quasi-government agency, an independent corporation owned by the federal government. The purpose of this special corporation is not to earn a profit, but to provide a service to all Americans. Amtrak owns most of the NEC and a few other relatively small segments. Throughout the rest of the country, Amtrak pays a fee to freight railroads or commuter agencies to use their tracks. Approximately 70% of the miles traveled by Amtrak trains are on tracks owned by freight railroads. Amtrak owns the rolling stock (locomotives and cars) that are used on National Network and NEC trains.

Coordination with “host railroads”, usually one of the Class I railroads, is vital for safe and efficient passenger rail operations. Most commuter, regional and intercity passenger rail services in the U.S. run on tracks shared with freight trains. VIA Rail has a similar arrangement in Canada. Additional freight capacity facilitates more passenger rail frequencies, fewer delays and faster service. However, on-time performance is a persistent and on-going issue. Lack of sufficient maintenance and capital infrastructure work by the host railroads also hurts the safety and reliability of passenger service. Under Federal law, the Class I railroads have common carrier obligations to serve the public interest. This includes sufficient accommodation of passenger trains. Passenger trains — which serve their customers on a schedule -- should be given preference on the tracks to alleviate the chronic and unacceptable late arrival problem that plagues long-distance passenger rail service in this country and makes it less attractive to potential customers.

The 1980 Staggers Rail Act (Public Law 96-448) is widely credited with restoring profitability to the freight railroads and supposedly reversing their historic loss of market share to trucking. However, the railroads’ pursuit of maximum profit in freight hauling has often conflicted with allowing passenger trains to run on time, or

accommodating more of them. Federal law requires that the freight railroads share their tracks with Amtrak and to provide dispatching preference to passenger trains. In practice, however, congestion of shared tracks has often led to delays and interruptions to Amtrak trains, earning them a reputation for chronic lateness. Amtrak is often blamed for its own unreliability, despite it usually being the fault of the freight railroads and their constrained infrastructure. At the end of 2020, the Federal Railroad Administration issued a new rule establishing a minimum standard to measure on-time performance by host railroads, which was unsuccessfully fought in the courts by freight railroads⁵³. In spite of these legal rulings, Amtrak continues to have difficulty sharing freight railroad lines, to the detriment of passenger service. In December 2022, Amtrak brought a regulatory complaint against the Union Pacific Railroad due to the ‘abysmal’ on-time performance of the Sunset Limited caused by freight train interference⁵⁴. The filing argues that many of the delays incurred by the Sunset Limited are “attributable to UP corporate decisions, operational practices, or failures that result in systemic violations of Amtrak preference rights and cause substandard [customer on-time performance]”. Among those, it says, are that UP regularly runs freight trains longer than sidings along its route; when UP dispatches freight trains that do not fit into sidings, “the Sunset Limited trains must follow that non-fitter, which can result in hours of passenger delay.”

Due to budgetary constraints, the Amtrak long distance trains often have been poorly maintained, and break down quite often. In spite of inconvenient and slow schedules, often unreliable service, and the poor condition of much of the equipment, the long-distance Amtrak trains are well-patronized. When people can travel by train, they do. Yet 142 cities with a population of over 100,000 have no long-distance passenger train service. Two dozen of these are urban areas with a population of over one half million. Major cities unserved by Amtrak include Phoenix, Las Vegas, Columbus, Nashville, Lexington and Louisville. There are 35 cities with a population of over 100,000 that have long distance train service within 30 miles, but not directly to the city. Passenger train trips to and from these cities assume substantial driving.

Amtrak long-distance, or intra-regional trains, provide

53. <https://www.freightwaves.com/news/federal-railroad-administration-finalizes-on-time-performance-rule>

54. <https://www.trains.com/trn/news-reviews/news-wire/amtrak-asks-federal-regulators-to-investigate-union-pacific-handling-of-sunset-limited/>

great economic and social benefits to the many rural towns and regions they serve. The total local economic benefits across the U.S. of Amtrak long-distance trains are estimated to be at least several times greater than the cost to operate them⁵⁵. The following is a quotation from an October 2021 letter of the U.S. Department of Transportation from the Rail Passenger Association of California and Nevada:

Long-distance Amtrak trains allow the option of traveling to a large matrix of cities big and small throughout the US. These trains also bring out-of-state visitors... for vacations, to attend college and to visit family and friends. The Amtrak long-distance trains are also essential for interregional transportation within states.

These long-distance rail routes not only serve underserved rural areas, they also represent key frequencies in existing and emerging corridors. Amtrak long-distance service offers a more energy efficient alternative to driving or flying these routes fulfill the goal of reduced GHG emissions.

Amtrak long distance trains are essential for economies of rural, smaller, or under resourced communities across the nation. Serving rural cities across America that have limited or no air or motor coach service, providing an option for those who cannot fly or drive for medical or physical reasons these routes expand accessibility for rural residents. Utilizing existing transportation assets (i.e., freight rail infrastructure), these routes reduce environmental impacts. By facilitating options for those who choose to live dependent on non-auto modes these routes advance quality of life, more long-distance passenger rail service options add to system resiliency and safety. Frequencies of long-distance trains should be at least doubled from the present once per day departures. Amtrak's long-distance routes generate strong economic activity. These routes also aid rural cities in maintaining and enhancing their often historic downtown businesses.

More Federal support for Amtrak long-distance passenger service will also benefit freight rail. One recent example is that of communities in Kansas, Colorado and New Mexico along the route of the Amtrak Southwest Chief stepping up to help secure funding for infrastructure projects that kept the train in service. In particular, the federal TIGER grant awarded to Colfax County, New Mexico for maintenance and refurbishment of the BNSF-owned line over Raton

Pass will also benefit freight trains which could use the route.

One important benefit to rural travelers provided by the Amtrak long-distance trains is a safer alternative to driving. Rural residents make up 19% of the U.S. population, but account for 49% of the total number of traffic fatalities nationwide, due to higher per-capita driving rates⁵⁶. There are also many urban and rural residents alike who do not “choose” to live auto-free. They must live auto-free because they might be too young or too old, have a disability that does not allow them to drive, or they might not be able to afford to buy, insure and maintain a car.

Today's long-distance passenger service is a skeletal relic of the past national network, representing the last survivors of the extensive railway system that served American travelers in the 1950s and before. That pre-Amtrak system included not only the survivors that Amtrak operates, but many other routes and schedules which no longer exist. There were trains that made many local stops. There were dedicated express mail trains, with a single coach for occasional express passengers, making few stops and very good time. There were mail trains that made an extended stop at every station, again with a single coach for occasional passengers. And there were the premium trains, meant specifically for comfortable, long-distance travel, of which our few Amtrak trains are the descendants. A restructured Amtrak system that could restore much of this historic legacy would feature fast, frequent trains between cities on 'regional length' routes (over 750 miles). The sparsely populated areas between major cities would be addressed by introducing more long distance trains. For example, an extended long distance service might be St. Paul, Minnesota to Spokane, Washington, connecting with the frequent regional trains between Chicago and St. Paul and between Seattle/Portland and Spokane.

An essential step for improving Amtrak long distance service is the acquisition of new equipment: there are currently not enough locomotives and passenger cars in a good state of repair. The existing Amtrak Superliner fleet has too many passenger cars that are out of service, in need of repairs or rebuilding after several wrecks in the past few years. A massive program of repair, refurbishment, and rebuilding of the existing Amtrak long distance fleet is urgently needed. Also urgent is Amtrak ordering all-new rolling stock for both long-distance and corridor/regional trains. Amtrak management needs to make this a priority, and Congress needs to allocate

55. https://www.railpassengers.org/site/assets/files/25442/economic_benefits_2022_final.pdf

56. https://railpassengers.org/site/assets/files/25442/national_network_rural_mobility_2022_final.pdf

the funds for large Amtrak equipment purchases. Also needed is more funding for hiring, training, and retaining more crew members.

The Amtrak long distance service should have close and convenient connections with regional trains. Service should be arranged to allow a passenger from a small town to make a useful day trip to and from a regional large town or city. In order to attract a reliable ridership base, there should be at least two trains in each direction per day. With track infrastructure improvements, normal operating speed for long distance passenger trains should be increased wherever possible.

Passenger trains could easily carry long distance express and other lightweight freight (package shipments carried in high-speed box cars or in trailers), as described above in the freight rail section. That could include containers and semi-trailers carried on cars capable of operating at the speed of passenger trains. These trains should operate between major cities, scheduled for integrated operation with regional and commuter trains. On some routes, there may be enough ridership overlapping the regional and long-distance segments of the routes for the long distance to run through to the hub city of the regional service even if the train is not carrying express freight. However, almost all long-distance train routes should be used for express freight shipments.

Current business practice, when work in a distant city is necessary/can't be avoided, is to take an early flight, attend to business, then return on a late flight. That results in uncomfortably long work days and unnecessary air travel. An overnight train averaging about 85 mph will take 12 hours for a 1,000 mile trip. This once-popular service in Europe is becoming popular there again. Another reason to strengthen the Amtrak long-distance network is the overnight service these trains already provide.

STATE-SUPPORTED AMTRAK ROUTES

State-supported trains provide service among cities and towns on routes generally up to about 500 miles long. Most of these corridors are existing rail lines, running parallel to interstate highway routes. Some states believe that passenger rail service, in addition to what Amtrak provides on the national network, is valuable or important enough for them to fund their own trains. Of the 54 Amtrak routes, only 28 are part of the national passenger rail system. The remaining 26 are funded by 17 states. These states pay Amtrak to operate their trains. The state services have more trains, operated at convenient times. Nine of the 26 routes have five or

more trains each way per day; and four have nine or more trains each way daily.

Currently, states that wish to add regional service using Class I railroad tracks and Amtrak crews and rolling stock, must fund a significant portion of this service themselves, including purchase of their own locomotives and passenger cars, and sometimes track infrastructure. Thus, Amtrak state-supported services tends to be in states with large populations such as California, New York, Illinois, Virginia, and Michigan.

HIGH SPEED RAIL

There is an ultimate need, in order for rail to be competitive with air travel, to eventually develop a high-speed rail network in the US. The International Union of Railways (UIC) defines High Speed Rail (HSR) by three categories:

Category I – New tracks specially constructed for high speeds, allowing a maximum running speed of at least 250 km/h (155 mph).

Category II – Existing tracks specially upgraded for high speeds, allowing a maximum running speed of at least 200 km/h (124 mph).

Category III – Existing tracks specially upgraded for high speeds, allowing a maximum running speed of at least 200 km/h (124 mph), but with some segments restricted to a lower speed (for example due to topographic constraints, or passage through urban areas)

Many national HSR systems have proven to dramatically reduce the GHG emissions of transportation, by taking significant number of domestic intercity passengers away from more polluting modes of air and automobile travel. These include Japan, France, Italy and Spain. Capitalizing on their HSR network, in April 2022 the French government announced a proposal to phase out all domestic airline⁵⁷ service where an alternative rail journey of under 2.5 hours in length is available⁵⁸. The ban currently covers three routes between Paris, Bordeaux, Nantes, and Lyon; and three more routes could be added — between Paris Charles de Gaulle and Lyon and Rennes, and between Lyon and Marseille — if rail services improve⁵⁹. Beyond France, other European lawmakers have proposed similar bans, with countries like Spain, Germany, and nations throughout Scandinavia considering such legislation. Austria, for one, has already begun enacting similar policies. Here in the U.S., the

57. <https://www.cntraveler.com/story/how-short-haul-flight-bans-are-transforming-european-travel>

58. <https://www.railway-technology.com/analysis/french-short-haul-ban-only-possible-thanks-to-rail>

59. <https://www.politico.eu/article/eu-greenlights-frances-short-haul-ban-but-only-on-3-routes>

highest speed train, the Acela, has captured a significant portion of riders who would otherwise go by air along the Northeast Corridor. As the northeast Acela corridor is upgraded using IIJA funding, it would be likewise feasible to limit short-haul air flights along this corridor.

The HSR service in the rest of the world is an extension of existing regional and inter-regional rail systems that connect to HSR stations. Even as the need arose for entirely new high-speed routes, European high-speed trains continued to use the conventional network near city terminals. That facilitated connections and made the infrastructure much less expensive than it would be with entirely new lines in urban areas. High speed trains stop at few stations, a requisite of high-speed operation and short travel time. To be useful, the high-speed trains must be integrated into a network of conventional speed trains, transit, and buses.

High speed rail service takes a long time and large amounts of money to develop; but so did the Interstate highway system. Once a region has established a complete and effective regional and long-distance rail service, expansion into HSR can be an appropriate next step. Speed should meet the needs of the service rather than an arbitrary goal: cost and safety, among other concerns, can affect the practical maximum speed of a train. Whenever practical, HSR trains should use the conventional network to reach urban areas, rather than needing high cost dedicated routes that require expensive land acquisitions or extensive tunneling.

HSR infrastructure is costly to build and maintain. An all-new rail line requires a substantial amount of property. Although rail transportation is the most environmentally friendly land transport, new rail line construction can have substantial local environmental impacts. New rail lines and new alignments for existing rail lines should be developed for maximum possible utilization. A new HSR line for trains operating at 200-270 mph can accommodate two trains (one train each direction) on eight minute headway or less. That's 240 round trips during a 16 hour business day. The need for new HSR-only rail lines must be considered carefully: the benefits weighed against costs.

A few examples of daily service frequency and ridership numbers on dedicated HSR routes before the pandemic include:

- Paris - Lille (TGV) 24 round trips (about 8,400 seats each direction)
- Nürnberg - Ingolstadt (ICE) 34 round trips (about 12,750 seats each direction)
- Madrid - Barcelona (AVE) 42 round trips (14,700

seats each direction)

- Köln - Frankfurt 57 (ICE) round trips (about 21,375 seats each direction)
- Tokyo - Shin Osaka (Shinkansen) 153 round trips (about 202,400 seats each direction)

To get an idea of what high-speed ridership would be along a particular corridor, it helps to look at the available airline seating between its endpoints. As a point of reference, the smallest of these five HSR services listed (Paris-Lille) should be about the level of minimum expected traffic that economically justifies investing in a new HSR line on dedicated right of way.

HSR projects in the U.S.

The only projects of true HSR under construction in the U.S. is the California High Speed Rail (CHSR) project and the Brightline West. CHSR will connect Los Angeles to San Francisco in 2 hours and 40 minutes (in Phase 1). The CHSR system will be 100% electrified and powered by renewable energy, with trains running up to 220 mph. Brightline West will connect Los Vegas, Nevada thru Victorville to Rancho Cucamonga, and will have speeds up to 200 mph along the I-15 Corridor⁶⁰.

The initial operating segment of the CHSR project, between Merced and Bakersfield, a length of 171 miles, is currently under construction in the Central Valley. This first CHSR passenger service between Merced and Bakersfield is expected to open around 2029-2030. Extensions to San Jose and San Francisco, Bakersfield to Palmdale and LA, and from LA to Anaheim are expected to be completed in the early 2030s. Sierra Club California supported Proposition 1A in 2008, which provided funding to start building California HSR. An interim service of high-speed rail in the Central Valley will allow travelers to access the Altamont Corridor Express (ACE) service in Merced, which will soon have frequent regional rail service to Stockton, San Jose, Sacramento, and the east Bay Area. The Amtrak San Joaquins service to Oakland and Sacramento will augment CHSR and ACE. And, frequent bus connections from Bakersfield to Southern California will provide connection until that CHSR segment is completed. According to the California High Speed Rail Authority (CHSRA) business plan, the completed CHSR system will remove the equivalent of more than 400,000 cars from roads each year. LA-San Francisco is one of the top ten busiest domestic airline routes in the U.S., with nearly 250,000 total seats daily (both directions combined, or nearly 125,000 seats each way)⁶¹. Airport expansion in California is unlikely. The only

60. <https://dailyhive.com/vancouver/brightline-west-high-speed-rail-las-vegas-los-angeles>

61. <https://www.oag.com/busiest-routes-right-now>

proposed large airport expansion project is for Oakland International Airport, which is facing significant local opposition. However, traffic between the Bay Area and LA is only one segment of the CHSR project's passenger market: the Central Valley region has fastest growing population in California. CHSR will facilitate travel within the Central Valley, and between the region and coastal Northern and Southern California population centers. Fresno and Bakersfield combined have more people than San Francisco.

As of mid 2023, 423 miles of the 500-mile Phase 1 San Francisco-Anaheim system is environmentally cleared with approved Environmental Impact Reports/Statements. The remainder will be environmentally cleared by 2025. For a megaproject the scale of the CHSR project, these environmental clearances of the different project segments are critical milestones, and huge steps forward to getting construction started where it has not already. They shield the project from the majority of lawsuits, making the project attractive to the private sector (largely for station-oriented development). The CHSR project, in conjunction with the related San Jose-San Francisco electrification of Caltrain, is important for starting rail electrification on a broad scale throughout the U.S., building up industry capability for electrification. The costs of the CHSR project (mid-level estimate of 500-mile Phase 1 is currently \$106 billion⁶²) are actually significantly less per mile than similar projects currently being built around the world. The first phase of HS2 project in England is much shorter (109 miles) but has an estimated total cost of £44.6 billion [\$55 billion], more than double the per-mile cost of CHSR. The cost of adding freeway lanes or airport capacity equivalent to that of the statewide high-speed rail network is estimated to be more than twice as much as high-speed rail and would dramatically increase greenhouse gas emissions. The cost of California HSR Phase I also must be compared to the combined total of tens of billions of dollars' worth of unfunded highway and freeway expansion projects proposed by the various public agencies in California. The Brightline West HSR project between Southern California and Las Vegas is likely to begin construction in 2023, pending funding and environmental approval. In February 2023, Brightline West announced a major project labor agreement with California and Southern Nevada building trades unions⁶³. Another private HSR initiative in the U.S., the proposed

Texas Central between Dallas and Houston, appears to have stalled recently⁶⁴.

Several "ultra-high speed" technologies such as maglev and "hyperloop" have been discussed for major transportation corridors in the U.S. The world's first commercial maglev train has operated between Shanghai's central business district and airport since 2004, reaching top operational speeds of 431 km/h (268 mph). However, the technology has proven to be far more expensive than conventional HSR systems. The hyperloop concept is still completely unproven as a useful commercial form of transportation, and is likely many decades away from being practical⁶⁵.

Freight and HSR

Germany operates HSR at up to 155 mph in mixed traffic (that is, using the same lines as lower-speed trains), and has one 186 mph line that can accommodate occasional light freight trains. Freight trains in Germany typically operate at 60 mph. This is partially to avoid freight trains using inordinate amounts of line capacity and energy. In the past, they have operated at speeds up to 90 mph, but this turned out to be too costly to be commercially viable, and unnecessary for most freight. The weight per axle of U.S. freight trains is typically 36 to 39 tons. A HSR line shared with U.S. freight trains, as they are now, is not practical. The high axle loading affects the condition of the track, and with U.S. freight trains, there is a substantial chance of shifting cargo, and react unpredictably to dynamic forces within the train. Long trains can be going uphill and downhill in several places at the same time, sometimes breaking couplings or causing derailments if a sudden stop is attempted. A loaded lightweight express freight train in Europe, however, would have a lower axle loading of about 20 tons and would be short, around 30 cars. Operating such light freight trains in mixed traffic with HSR trains at 155 mph or perhaps 186 mph could be practical.

REGIONAL/COMMUTER RAIL

Commuter rail trains operate on standard railroads, the national network, in urban areas. They share the tracks with freight trains, regional passenger trains, and long distance passenger trains. In the U.S., the tracks used by commuter trains are owned by one of the freight railroads, Amtrak, or a government agency. All of the commuter rail services are owned and operated by public agencies, although several contract the operation to private companies. 28 U.S. cities have commuter

62. <https://hsr.ca.gov/wp-content/uploads/2023/03/2023-Project-Update-Report-FINAL-022823.pdf>

63. <https://www.gobrightline.com/press-room/brightline-west-high-speed-rail-labor-coalition>

64. <https://www.texastribune.org/2022/08/30/texas-high-speed-rail-dallas-houston>

65. <https://www.nytimes.com/2022/09/22/business/hyperloop-transit-virgin.html>

rail service. Boston, New York/Northern New Jersey, Philadelphia, Chicago, San Francisco Bay area, and Los Angeles have extensive, comprehensive commuter rail service on several routes. 18 of them have only one route. Several of the single route systems provide only partial service: during peak hours, in and out of the central city; or only on weekdays. Some have limited off peak service. Both arrangements limit the general utility of the service. Several other cities, such as Austin, have recently passed bond measures to begin development of new light-rail systems in their cities.

For passenger rail transportation networks worldwide, there is a new emphasis on regional rail, designed to serve more variety of trips than just commuting to work. Commuter service is often oriented primarily to commuters, people who go to a major city center in the morning to go to work and return home to suburban areas in the evening. For example, the Altamont Corridor Express (ACE) operates this way. On many U.S. commuter rail systems, service between those two times is often limited to only occasional trains, or even nonexistent. Regional rail is increasingly the preferred term of rail advocates around the world, as opposed to just ‘commuter’ rail. Service should be developed with the concept of suburban service in mind; that is, supporting shopping and recreation as well as work.

Regional or suburban service needs to accommodate travel that is not associated with commuting. Even commutes have expanded, since the expressway/freeway systems have made the central city obsolete as a primary location for employment, and what were once bedroom communities are now often commercial centers in themselves. Trains need to run out of the city during commute hours; they need to accommodate day trips to a city between commuting times; and they need to run between suburbs, both during and between commute hours. Such service should include lines that encircle the city, like a belt, because many trips require travel between towns that are not along one of the lines radiating from the original urban hub. Some people drive because the rail option involves traveling further from where they are through the urban hub to where they are going than traveling between the places directly. Electrification is important for decreasing travel time for commuter/regional trains with frequent stops, as electric trains can accelerate faster than those powered by diesel. Electrification can reduce overall travel times on commuter rail lines by 15% or more. This makes the service more attractive to passengers, while reducing labor, maintenance and equipment costs.

Public agencies need to take the greatest possible

advantage of existing rail infrastructure for commuter or regional rail service, although some of them will require improvements to suit that purpose. New commuter service may require improvements to track and signal systems for higher speed; they may also require additional tracks for overtaking. These improvements will also benefit freight operation. Usually, almost all of these elements can be contained on existing railroad right of way. New passenger service can be started relatively quickly to new rail transit lines, and improved as more infrastructure is built.

RAIL TRANSIT

The largest amount of road transportation greenhouse gas emissions occurs in urban and suburban areas. For that reason, increasing rail transportation in urban and suburban areas for local and regional trips is critical for reducing GHG and VMT. Electric transit trains and buses massively decrease GHG emissions and other transportation pollution in urban and suburban areas throughout the world. Perhaps the biggest reason that many European cities have a per-capita carbon footprint a small fraction of many U.S. metro areas is the extent of frequent and convenient transit service, and developed patterns focused around rail transit and walking.

Unfortunately, the overall pace of new rail transit construction in the U.S. has fallen in the past decade⁶⁶, and civic leaders too often have mistakenly seen electric cars as a more promising climate solution than public transit⁶⁷. More funding from all levels of government is needed to support transit operations nationwide⁶⁸, especially with regards to the potential ‘fiscal cliff’ of reduced ridership during the pandemic⁶⁹. Local, state and Federal transit agencies must recognize that frequent, reliable, sustainable public transit is central to a climate solution and fund transit operations accordingly, for the health of societies and the planet.

Streetcars

The Streetcar (also known as tram outside of the U.S.) service is a self-propelled vehicle, almost always electric powered, using overhead contact wire. The track usually occupies the traffic lanes of streets and is shared with cars and trucks. The performance of streetcars in traffic is similar to that of buses, but they accelerate more quickly than buses and are generally more comfortable to ride in. They also perform better under snow or ice

66. <https://usa.streetsblog.org/2023/01/24/data-other-countries-are-building-transit-while-the-u-s-falls-behind>

67. <https://www.bloomberg.com/news/articles/2023-01-25/public-transit-gets-left-behind-in-us-climate-change-conversation>

68. <https://www.vox.com/future-perfect/23653855/covid-transit-fares-buses-subways-crisis>

69. <https://t4america.org/2023/01/31/transit-fiscal-cliff-or-transit-fiscal-doom>

conditions than do buses. Buses have a slight advantage in the ability to change lanes to avoid obstructions. However, the power consumption of a bus remains three times that of a rail vehicle. Passengers typically step up from street or curb level into a streetcar, much like a bus. A century ago, nearly every American city with a population greater than 20,000 had at least one streetcar line. By the 1960s, the vast majority had gotten rid of them. They were replaced by buses.

The argument for buses was that they are less expensive and can have more flexible routing. However, the subsidies bus service receives are hidden in the cost of the roads they use. Buses are overweight vehicles. Their effect on roadways is at least as much as and sometimes greater than the effect of large trucks. Bus routes may be easily changed, but they generally use the arterial streets, which have not changed since they were occupied by streetcars.

Some buses, generally called trolley buses, are electrically-powered, receiving power from an overhead contact wire like a streetcar. Trolley buses can change lanes, whereas a streetcar cannot, which somewhat limits the flexibility argument of comparison with streetcars. Not needing batteries as the main power source, trolley buses have the environmental advantage over battery-powered electric buses. They will not generate the volume of battery waste that non-trolley buses generate.

A small number of U.S. cities, notably Boston, Philadelphia, New Orleans, and San Francisco, retained an extensive streetcar network as part of the city's transportation system. The others removed all streetcar lines in favor of buses. Today, 20 U.S. cities have streetcar service. The Portland, Oregon streetcar system totals about 10 miles of route length. The rest are between one and five miles of route, some of them are primarily tourism-oriented rather than regular transportation for local residents. These streetcar lines are almost all twenty years old or less.

Elsewhere in the world, there are over 300 streetcar systems. Countries that have streetcar networks in at least several cities include China, Japan, Taiwan, Kazakhstan, Turkey, Austria, Belarus, Belgium, Czech Republic, France, Germany, Italy, Hungary, Latvia, Netherlands, Norway, Poland, Portugal, Romania, Russia, Slovakia, Spain, Ukraine, and United Kingdom.

Transit connections (whether between bus and bus, bus and streetcar, or either of these and a train or ferry boat) need to be close and convenient. There must be minimum waiting time at the connection, and there must

be minimal walking distance between boarding locations; and the scheduling must be dependable.

Light rail

Light rail is a modern (1970s) term that has an indistinct definition. It does not mean the rails are light weight. It means some aspect of the service is light (usually the weight of the passenger trains). The next step up in urban rail service is called heavy rail, rapid transit, or metro. Many U.S. cities that have heavy rail service call it subway, whether it is in a tunnel or on an elevated structure or embankment.

Light rail vehicles typically have less passenger capacity for their length than heavy rail transit vehicles, and generally operate in much shorter trains than heavy rail. Light rail generally operates on dedicated right of way, occupied exclusively by the rail line, or on special lanes of roads and streets, also used exclusively by trains. There are a few light rail systems that occupy traffic lanes in the same manner as streetcars. Light rail systems are electric-powered by overhead contact wires. Light rail lines have stations spaced farther apart than streetcar lines. Whereas streetcars are limited to the traffic speed limit, light rail service on dedicated routes operates at much higher speed, up to 55 mph.

Modern light rail is a descendant of interurban railroads. These were primarily passenger carriers, electric-powered and using equipment heavier and faster than streetcars, but not generally as large as conventional railroad cars. They operated on streets in the city, but on private right of way between cities. Many interurban lines also carried package freight, and had freight trailer cars to pull behind the passenger car. Some even had electric locomotives and performed conventional railroad freight service. In the early 1900s, there was an extensive network of interurban railroads in the U.S., over 15,000 miles in 1916. The interurban railroads were intended to be a profit-making venture. They suffered from inadequate revenue for the cost of building and maintaining the service. That is common in passenger transport, which is why virtually all passenger transport in the U.S. is provided by a government agency. The widespread expansion of the highway system, and the increase in automobile ownership, brought the end of most of the interurban rail lines. Only the four largest survived into the 1960s. Three of them finally succumbed to highway competition. The last is now operated by a government agency. However, in appearance and operation it looks much more like a standard rail commuter service than a light rail system. Today there are 25 light rail systems in the U.S, including

the four oldest systems that were opened before World War 2. Between 1936 and 1981, the era of the greatest new highway construction, many interurban lines were removed, providing a period of dormancy for light rail. No new interurban or light rail systems were opened during this period in the US. However, beginning in the 1980s, there began to be a revival of inter-city rail. Five new systems were opened in the 1980s, six in the 1990s and eight since 1999. Ten of the light rail systems consisted of only a single route connecting two points. The rest, generally the oldest, have two to seven routes. There are 15 light rail systems in Asian cities, 23 in Europe and three in Africa.

Light rail for freight

Light rail and streetcar lines can also be effective in providing freight transportation. The streetcar system of Zurich, Switzerland includes Cargotram service. The trains collect garbage and recycling, just as garbage and recycling trucks do in other places. In Dresden, Germany, until recently there were freight trams, which served as mini freight trains operating on the streetcar network, serving two Volkswagen plants which recently closed. This was the reason for the end of the freight tram of service. Streetcars were chosen for their advantages, available because of the extensive existing network. In the German cities of Karlsruhe, Kassel, and Saarbrücken, trams share a segment of conventional rail line with freight and passenger trains. Although it has proven to be safe, this arrangement is rarely allowed in the U.S. (one notable exception is BNSF freight trains running at night on the San Diego trolley line).

In the U.S., from 1900 until the mid-1930s (although a few larger ones lasted into the 1950s), interurban electric railroads, the ancestor of today's light rail, handled package and express freight intermodal and even carload freight in regular freight cars. Some trains were a combination of freight and passenger, either by having a freight compartment and a passenger compartment in one car, or by having freight and passenger cars in a train. Like today's light rail lines, interurban railroads were often located where standard railroads were not, in business districts and small population areas.

Today's light rail and streetcar systems should be examined for opportunities for them to replace some types of truck service with rail service, perhaps

connecting with small trucks for final delivery and pickup. Light rail lines to airports might have a branch line into the air freight section. Package freight might be moved in specialized containers designed for the purpose, easy to move onto or off of a train at a passenger platform and able to use the passenger elevator at stations. The service might operate in conjunction with a last mile freight service similar to the last mile passenger service, using a fleet of electric on-demand vehicles, similar to ride sharing services, that meet each train and follow a delivery and pickup route designed specifically for that trip before returning to the station to meet the next train. The potential of local freight on rail transit is especially important for growing e-commerce deliveries in urban areas.

Heavy rail mass transit

Heavy rail mass transit lines, also synonymous with the term rapid transit, are urban transit railroads that are located entirely on exclusive right of way, often on elevated structures or in tunnels. They use cars that have a greater capacity than light rail cars, operate in longer trains than light rail, and are faster than light rail trains. Heavy rail systems are generally built in the areas of densest population, so construction is expensive. Underground utilities (sewer, water, gas, electricity, communication, etc.) must be moved prior to or during construction. Right of way must be acquired and cleared for elevated structures. When a new transit system is considered, light rail is often seen as a compromise, using streets in some places as a less costly routing for the tracks. There are only 14 heavy rail systems in the U.S.: in New York City, Boston, Chicago, Washington DC, Philadelphia, Cleveland, Jersey City, San Francisco, Atlanta, Baltimore, Miami, and Los Angeles. Three of the heavy rail systems are extensive. New York City's system has a total of 248 miles of track, Chicago has 103 miles, and Philadelphia has a total of 53 miles. There are several routes in each system. The others vary from 14 to 48 miles in total length. A new fully automated heavy rail transit line, 20 miles long, is being constructed in Honolulu that will be the most technologically advanced transit system in the nation. Outside of the U.S., 191 cities have a heavy rail transit system. There are 30 new heavy rail systems under construction worldwide.

Railroad Training and Education

The success of improving the utilization of rail transportation depends upon restoring the U.S. railroad industry's knowledge of infrastructure design and utilization and the reliable movement of people and time-sensitive freight. Because of the focus on highways, much of the expertise in railroad design, construction, and operation in the U.S. has been lost. The maintenance and furthering of technical expertise requires an educational pathway to allow young people to enter the field. It also requires academic "homes" (departments or institutes) where innovation and research can be nurtured and realized. In the U.S., there are only three specialized university railroad transportation and engineering programs: University of Illinois at Urbana-Champaign (its rail program was founded over 100 years ago), Michigan Technological University (founded in 2007), and Penn State Altoona (founded in 2011). Their programs are relatively limited in scope compared to their European or Asian counterparts. There are 20 discrete, non-program courses offered at other U.S. universities, with the number of courses ranging from one to six at the various universities. There is a roughly 100:1 ratio of highway to rail academic funding in the U.S. (Tuning Transatlantic Cooperation in Rail Higher Education, Handbook for Rail Higher Education, 2011). The USDOT sponsors University Transportation Centers around the country⁷⁰, including the National University Rail Center at the University of Illinois at Urbana-Champaign⁷¹, the University Transportation Center for Railway Safety at the University of Texas Rio Grande Valley⁷², the Rail Transportation Engineering and Advance Maintenance center at the University of Nevada, Las Vegas⁷³. The University of Delaware offers a graduate engineering certificate program in railway engineering⁷⁴.

In the European Union, in contrast, there are nearly forty university programs in railroad transportation and engineering. Similar university railroad engineering and transportation programs are offered in India, Russia, China, Taiwan, and Australia. There are even entire universities in Russia and China that specialize in rail transportation programs. In Germany, the fundamental rail engineering courses are a requisite for all engineering students. Railroad programs in Chinese universities are

attracting students from English as a second language countries all over the world. The university rail programs in Europe and Asia are far more comprehensive in content than U.S. rail engineering programs, which concentrate more on how to build than what to build or how to use it. Engineering and operation cannot be separated in rail transportation as it can in highway transportation.

A full-scale railroad transportation and engineering program should be initiated in several colleges and universities throughout the U.S. Safe and dependable rail transportation also depends upon well-qualified individuals to operate, maintain, and manage the service. Short line railroads could be used in conjunction with a comprehensive technical training and apprenticeship program in railroad trades (operation, track and signal maintenance, vehicle maintenance, supervision, and management). Another important need is rail training and skills development for staff of state, regional and local transportation departments⁷⁵.

The USDOT/Federal Railroad Administration should implement:

- Comprehensive programs to train and educate current U.S. railroad personnel in designing and operating fast, frequent, reliable, and convenient rail passenger and freight service.
- Policy that will encourage trade school and universities to provide railroad engineering and operations programs, and fund such programs.
- Develop and implement policy that will facilitate the introduction of international best practices (European or Asian rail operations experts) into U.S. rail education and service provision.

The Federal Railroad Administration should fund and support 'Rail Tech Hubs', building up upon the Transportation Research Board's existing National Cooperative Rail Research Program⁷⁶. Such trackside facilities could host:

- High-end manufacturing and maintenance of electric locomotives and rail equipment ('rail industrial park' for several companies). Multiple companies on one site can share a skilled labor pool and a variety of specialists and consultants. Local skills and suppliers can exceed what a stand-alone factory can support.

70. <https://www.transportation.gov/content/university-transportation-centers>

71. <http://www.nurailcenter.org>

72. <https://www.utrgv.edu/railwaysafety>

73. <https://www.unlv.edu/railteam>

74. <https://railroadengineering.engr.udel.edu>

75. <https://www.route-fifty.com/infrastructure/2023/01/state-governments-railroad-expertise-gap/382034>

76. <https://www.trb.org/nccrp/nccrp.aspx>

- Sites for zero-emissions electric railroad technology demonstrations.
- University railroad engineering and research programs.
- Railroad employee technical training programs.
- A Rail Tech Hub could provide high-paying manufacturing jobs in the green technology sector, by attracting companies who manufacture zero-emissions electric locomotives, and intermodal railcars which reduce pollution by shifting more freight from truck to rail.

Next Steps: How the Sierra Club Can Advocate for Rail Transportation

As one of the nation's largest environmental organizations, with chapters and active volunteers in every state, as well as a strong presence in D.C. and in Puerto Rico, the Sierra Club should take a prominent lead in advocating for rail travel as an essential climate solution, including organizing and funding rail advocacy efforts in every state and region. The Federally-regulated nature of railroads in the United States means that rail is inherently a national issue, so leadership on this issue needs to come from the Sierra Club organization on a national level.

The Sierra Club should also seek to ally with rail workers' unions in rail advocacy efforts. Partnerships and coalitions with these unions can amplify and enhance our work by providing political strength and hands-on knowledge of the freight and passenger rail industry.

Individual Sierra Club members can

- Join rail and transit advocacy groups and encourage them to add climate emergency response, and reduction of localized air pollution, to their rail advocacy message. This includes passenger intercity regional rail, local rail transit, and freight rail.
- Contact Federal, state, and local government elected officials and tell them that rail transportation is an essential climate emergency response, and explain to them its myriad other public benefits. Ask them to direct public agencies (under their purview) aggressively pursue state and Federal funding for rail projects.
- Tell people you know, friends, family, co-workers, that rail transportation is a climate emergency response that is in dire need of support.

PUBLIC INVESTMENT FOR RAIL CAPACITY EXPANSION

Increasing the mode share of rail will require upgrading existing railroad corridors, especially those which parallel major highways. Faster, higher-performance rail lines will attract more passengers and time-sensitive freight. These upgrades include track replacement and upgrading for higher speeds, adding double – or triple mainline

tracks, new or extended sidings, and road-rail grade separation projects. A great improvement in rail service ultimately involves large infrastructure (e.g., track, signal, bridge) projects to configure existing lines to more effective use. However, the change in transportation emphasis from highway to rail can be started immediately. Infrastructure projects and associated increases in service can be pursued incrementally. There is no need to wait for the completion of a large-scale construction program. Well-planned rail capacity improvements will have many environmental, operational and economic benefits, such as:

- Eliminating much of the rubber-tire interchange of trailers and containers moving on city streets between rail intermodal terminals.
- Speeding the movement of trains thus making the rail mode more attractive resulting in a shift of traffic from cars and trucks to trains.
- Reducing the amount of time trains are delayed due to congestion.
- As a result of the above improvements generate fuel savings and a reduction in air pollution, especially with freight rail electrification.
- As rail is much more efficient than highways, and transportation is one of the basic "Factors of Production", increasing transportation efficiency will positively affect every sector of our economy – reducing costs and waste while encouraging economic growth.

State transportation agencies, while they are responsible for rail planning in each state, mostly lack the funding, expertise, and authority to implement their own plans. Indeed, in some states, the state transportation departments are specifically prohibited by law from funding rail improvements.

Local and state rail advocates should work with state elected and appointed leadership both to remove barriers to implementing rail projects, and at the same time to provide a new and robust legal and administrative framework– through legislation or administrative

actions – that would allow states to become partners in rail development. This could include direction and funding to state transportation departments to recruit and train employees with expertise in rail and public transportation. It could also include establishing and funding state rail authorities.

Since most railroad freight routes in North America are privately owned, government loans or grants for funding route capacity projects on privately-owned lines must be evaluated on their benefit to the public, and not just one railroad company. Rail routes through major terminals are often “joint facilities” — facilities used by two or more carriers, and often used by passenger as well as freight. That’s why it has been relatively easy to justify public funding for projects like the Alameda Corridor in Los Angeles, the two Kansas City “Flyover” projects, and the huge Chicago CREATE (Chicago Region Environmental and Transportation Efficiency) Program⁷⁷. Rail initiatives across the U.S., that have already attracted broad support, proposing public funding on freight railroad corridors, include:

- Grade separation projects- new underpasses or overpasses, which ‘grade separate’ roads and railroad tracks are very important for safety. They also eliminate the need for street traffic (cars, trucks, pedestrians, cyclists) to wait at railroad crossings.
- New overnight passenger train service (Amtrak or another long-distance passenger operator), between major cities that are 600 – 1000 miles apart should be implemented.
- Refurbishment of abandoned or lightly used branch rail lines.
- Rail infrastructure capacity and improvements in support of the Amtrak ConnectsUS plan announced in 2021, which proposed a variety of new short corridor services around the country⁷⁸.

NEAR TERM FOCUS: INFRASTRUCTURE INVESTMENT AND JOBS ACT (IIJA) OF 2021

The federal Infrastructure Investment and Jobs Act (IIJA) of 2021, also known as the Bipartisan Infrastructure Law (BIL), presents this country with a perhaps unique chance to invest in a major way to greatly improve our nation’s rail system and get much of it electrified. We cannot miss this opportunity, the first time in decades, that so much funding is available to expand rail in the U.S., for transformational new

⁷⁷. <https://www.createprogram.org>

⁷⁸. <https://www.amtrakconnectsus.com>

build projects to shift more passengers and freight from roads and onto rail (with dramatic reductions in GHG emissions). Rail must be a priority for reducing transportation emissions. Make no mistake, though, about this unprecedented amount of money. It is but a small start on the path to reversing over a century of damage that has been inflicted on the U.S. rail transportation system through misguided government policy and regulation, subsidies for competing modes, and the railroad corporations ignoring any sense of public interest under a laissez faire approach in the last four decades.

The IIJA’s Corridor Identification and Development Program will “identify new intercity passenger rail corridors, develop the necessary service planning elements, and create a non-Northeast Corridor Project Pipeline for associated capital projects.” It is critical that these projects then be funded by significant federal dollars so that the nation’s sparse system of intercity and regional rail can begin to be filled in.

Sierra Club chapters should work with their state leaders to identify state funding sources for regional and intercity rail. The current system that exists in many states outside of the northeast and California, with federal funding for minimal intercity and long-distance Amtrak service, and local funding through regional transportation agencies for local public transportation, leaves a big gap in the middle, with few or no identified funding sources for regional and state intercity rail. This leaves much of the population of many states minimally served - if even served at all - by public transportation including rail.

Sierra Club local chapters can support local and state governments going after Federal grants for beneficial rail projects. To find rail projects worthy of support, a good place to look is state and regional transportation plans, state rail plans, multi-state/regional and corridor rail plans. Local public transport and passenger rail advocacy groups have developed ‘wish lists’ of priority rail capital projects. The Sierra Club can educate states, counties, cities, tribes about the grant opportunities coming available soon through the information sources listed below.

Working with local rail and transit advocacy groups, Sierra Club members and staff can prepare draft outlines of grant applications which local and state government agencies can use to help put together grant applications for rail projects. Given the long timeline of consensus-building of stakeholders, finding matching and long-term operating funds, the planning for the grant application

process should begin long before the grant applications are submitted. Strong local support is necessary for any rail project to succeed.

- A successful rail project will require building coalitions, and finding local champions:
- Elected officials in cities, counties, states, and tribes.
- Public agency staff, including management.
- Businesses, chambers of commerce, economic development agencies.
- Environmental and environmental justice organizations.
- Rail and transit advocacy organizations.
- Labor groups.
- Other stakeholders.

For BIL FRA grant programs, the main portal of information is this webpage: railroads.dot.gov/BIL

- Consolidated Rail Infrastructure and Safety Improvement (CRISI) program grants (section 22303)
- Restoration and Enhancement Grants (section 22304)
- Federal-State Partnership for Intercity Passenger Rail grants (section 22307)
- Railway-Highway Crossings (section 11108), and Railroad Crossing Elimination Program grants (section 22305)
- National Network grants to Amtrak (section 22101)

These are also annual programs, with opportunities to apply each year for the next few years. FRA will regularly release the Notice of Funding Opportunity (NOFO) for each grant. All NOFOs will be published in the Federal Register as well as on FRA's Competitive Discretionary Grants page as the application process opens.

<https://railroads.dot.gov/grants-loans/competitive-discretionary-grant-programs/competitive-discretionary-grant-programs>

FRA BIL resources table:

<https://railroads.dot.gov/sites/fra.dot.gov/files/2022-01/BIL%20Tools-Resources%20Table%201.21.22.pdf>

In addition to the grant funding programs, the BIL enacted these critical rail policy reforms and new programs (based on summary provided by Rail Passengers Association⁷⁹):

Sec. 22201. Amtrak Findings, Mission, and Goals: Amends Amtrak's mission and goals to emphasize its role in providing service to rural communities, recognize the importance of long-distance routes, and encourage Amtrak to maximize the benefits of Federal investment (as opposed to minimizing costs).

Sec. 22202. Composition of Amtrak's Board of Directors: Revises the composition of Amtrak's Board of Directors to ensure representation across the Amtrak network (two from NEC states, two from LDR states, and two from State-supported states), and requires annual engagement with the disability community, Amtrak employees and the general public.

Sec. 22203. Station Agents: Requires ticket agents at each Amtrak station building that averages at least 40 passengers per day.

Sec. 22204. Increasing Oversight of Changes to Amtrak Long-Distance Routes and Other Intercity Services: Requires Amtrak to include information regarding any change or plans to change a route, frequency of service, or station stops in its annual operations report and its general and legislative annual report to Congress.

Sec. 22206. Improved Oversight of Amtrak Spending: Requires Amtrak to provide a much greater level of detail on its spending in annual reports to Congress.

Sec. 22208. Passenger Experience Enhancement: Eliminates requirement that food and beverage services on trains may only be provided if their revenues break even during a fiscal year. This section also directs Amtrak to establish a working group—including nonprofit organizations representing Amtrak passengers—to develop recommendations to improve Amtrak's onboard food and beverage services.

Sec. 22210. Protecting Amtrak Routes through Rural Communities: Prohibits Amtrak from discontinuing, reducing the frequency of, suspending, or substantially altering the route on any segment of any long-distance route if Amtrak receives adequate funding for that route.

Sec. 22111. State-Supported Route Committee: Directs the State-Amtrak Intercity Passenger Rail Committee (SAIPRC) to update its cost allocation methodology to improve accountability and transparency. Requires Amtrak to provide monthly invoices to each State, as well as SAIPRC, describing operating costs of State-supported routes.

Sec. 22212. Enhancing Cross Border Service: Requires Amtrak to report to Congress on how to improve Amtrak passenger rail service between the United States and

⁷⁹ <https://www.railpassengers.org/happening-now/news/blog/whats-in-the-investment-in-infrastructure-and-jobs-act-ija>

Canada, identifying challenges such as delays associated with customs and immigration inspections.

Sec. 22214. Amtrak Daily Long-Distance Service Study: Directs the U.S. DOT to conduct a study to evaluate the restoration of daily intercity rail passenger service along any Amtrak long-distance routes that has been discontinued, and any Amtrak long-distance routes that, as of the date of enactment of this Act, occur on a nondaily basis. FRA Amtrak Daily Long-Distance Service Study website: <https://fralongdistancerailstudy.org>

Sec. 22306. Interstate Rail Compacts: Establishes a competitive grant program to provide Federal funding for interstate rail compacts—analogueous to the Southern Rail Commission which has led the Gulf Coast Restoration project. Grants will cover costs of administration, systems planning, and operations coordination. Grants to IRCs will not exceed \$1 million annually and require a local funding match of at least 50 percent.

Sec. 22308. Corridor Identification and Development Program: Requires the USDOT to establish a program to add and improve intercity passenger rail corridors. Rail corridors selected for development would work with USDOT and relevant States to prepare a plan outlining capital projects needed to establish service. As described in the Federal Register⁸⁰:

“FRA intends for the Corridor ID Program, as it grows and matures, to become the primary means for directing Federal financial support and technical assistance toward the development of proposals for new or improved intercity passenger rail services throughout the United States. Development activities under the Corridor ID Program will include the preparation of Service Development Plans, the identification of capital projects necessary to support a corridor, and the advancement of such projects, as appropriate, through preliminary engineering (PE) and the National Environmental Policy Act (NEPA) process, for the ultimate purpose of advancing the corridor for subsequent and immediate implementation (comprising final design and construction activities). Importantly, the selection of a corridor into the Corridor ID Program will represent a decision by FRA to provide financial assistance for the completion of these pre-implementation corridor development activities, subject to the successful completion of program requirements and the availability of funding.”

80. <https://www.federalregister.gov/documents/2022/05/13/2022-10250/establishment-of-the-corridor-identification-and-development-program>

Solicitation released December 2022, with applications due March 2023.

The Corridor ID Program has three steps for applicants:

1. Corridor development initiation and scope, schedule, and cost estimate for preparing a Service Development Plan
2. Service Development Plan
3. Project Development

FRA Corridor Identification and Development Program website:

<https://railroads.dot.gov/corridor-ID-program>

Sec. 22309. Surface Transportation Board Passenger Rail Program: Directs the Surface Transportation Board to hire additional full-time employees to assist in carrying out its passenger rail responsibilities.

This Rail Passengers Association (RPA) webinar from January 2022 has a lot of good information from Federal Railroad Administration staff about new funding opportunities in the IIJA, and how state and local governments need to go after them:

<https://www.railpassengers.org/resources/webinars/rail-passengers-webinar-series-understanding-the-fras-expanded-grant-application-process-january-26-2022/>

Jim Matthews, RPA President and CEO, stated in this webinar:

“Whether you are a local official, an MPO [metropolitan planning organization], elected, appointed, passenger advocate, it’s really important to understand the mechanics of who is eligible to apply for these funds, what that application process looks like, and the criteria which FRA are going use to evaluate project submissions. What kind of train service is built really is going to depend on the quality, and the variety, of the project applications which FRA gets”.

Also recommended is the High Speed Rail Alliance’s February 2023 webinar “Understanding the FRA’s Expanded Grant Application Process”:

<https://www.hsrail.org/events/federal-process-how-advance-your-passenger-rail-project>

FRA Guidance on Development and Implementation of Railroad Capital Projects:

<https://railroads.dot.gov/elibrary/fra-guidance-development-and-implementation-railroad-capital-project>

Federal Transit Administration grant programs, which can be used for passenger rail and rail transit:

<https://www.transit.dot.gov/grants>

<https://www.transit.dot.gov/BIL>

Positive Train Control Grants Program

<https://www.transit.dot.gov/funding/grants/positive-train-control-grants-program>

Competitive Grants for Rail Vehicle Replacement Program:

<https://www.transit.dot.gov/grant-programs/competitive-grants-rail-vehicle-replacement-program>

State of Good Repair Grants – 5337:

<https://www.transit.dot.gov/funding/grants/state-good-repair-grants-5337>

Capital Investment Grants – 5309:

<https://www.transit.dot.gov/CIG>

<https://www.transit.dot.gov/capital-investment-grants-5309>

Metropolitan & Statewide Planning and NonMetropolitan Transportation Planning - 5303, 5304, 5305:

<https://www.transit.dot.gov/funding/grants/metropolitan-statewide-planning-and-nonmetropolitan-transportation-planning-5303-5304>

Transportation Planning:

<https://www.transit.dot.gov/regulations-and-guidance/transportation-planning/transportation-planning>

All Stations Accessibility Program:

<https://www.transit.dot.gov/ASAP>

Flexible Funding Programs - Congestion Mitigation and Air Quality Program - 23 USC 149:

<https://www.transit.dot.gov/funding/grants/grant-programs/flexible-funding-programs-congestion-mitigation-and-air-quality>

Flexible Funding Programs - Surface Transportation Block Grant Program - 23 USC 133:

<https://www.transit.dot.gov/funding/grants/flexible-funding-programs-surface-transportation-block-grant-program-23-usc-133>

RAILWAY SAFETY ACT OF 2023

In March 2023, Ohio Senator Sherrod Brown introduced the bipartisan Railway Safety Act of 2023, in the wake of the East Palestine disaster in his state⁸¹.

MEDIUM TO LONG-TERM RAIL LEGISLATION AND POLICY

Property Tax Abatement for Rail Improvements

Property taxes for private railroad companies could be abated for, say, 20 years for any rail improvement that expands track capacity, increases speed or electrifies operations.

National Infrastructure Bank

Legislation in Congress has been introduced in recent years to create a long-discussed National Infrastructure Bank⁸². This new financial institution could be a steady funding source for rail capital projects, to complement funding from other Federal, state and local sources.

Federal Railroad Reform

In August 2022, the Freight Rail Shipping Fair Market Act, was introduced by Chair of the Subcommittee on Railroads, Pipelines, and Hazardous Materials Donald M. Payne, Jr. (D-NJ), Chair of the House Committee on Transportation and Infrastructure Peter DeFazio (D-OR), Chair of the House Committee on Agriculture David Scott (D-GA), and Chair of the Subcommittee on Livestock and Foreign Agriculture Jim Costa (D-CA), and “has gained support from captured freight rail customers who stand to benefit from provisions that would create a more fair and competitive marketplace”⁸³.

Nationalization:

Throughout the world, rail transportation was nationalized because nations determined that rail transportation was too important to entrust to private corporations. It is not much different than public ownership of highways, roads and streets, ports, dams, and airports. There are many sections of railroad track and right of way across the U.S. that have been purchased from private railroad companies by state or local governments. There are many proponents of nationalization of the U.S. railroad network. They observe that the other modes of transportation, highway, air, and navigation, are conducted on publicly-owned facilities and rail transportation should be likewise. Some states, counties, and regional transportation agencies

81. <https://www.brown.senate.gov/newsroom/press/release/sherrod-brown-rail-workers-springfield-leaders-local-business-owners-push-for-railway-safety-act#:~:text=Brown%20led%20a%20bipartisan%20group,others%20in%20Ohio%2C%20including%20residents>

82. <https://www.nibcoalition.com>

83. <https://transportation.house.gov/news/press-releases/support-for-freight-rail-shipping-fair-market-act-grows-as-shippers-demand-relief-from-costly-unfair-practices>

across the nation have purchased segments of track from private railroad companies. The Alaska Railroad was originally built by the Federal government about a century ago, but is now owned and operated by the state government. However, a full-scale nationalization of the entire (or a majority) of the U.S. railroad system is not a feasible solution in the U.S. for the foreseeable future. Railroad corporations own an immense amount of property: at least several hundred billion dollars worth. Fair compensation would need to be determined, which would involve a great amount of non-productive expense in litigation. The litigation and negotiation process would take a very long time.

The U.S. government need not own a transportation facility to control it. Commercial airports are typically publicly owned facilities. Ownership is local, e.g., a city, county, or port district, but operation is under strict federal control. The same arrangement can apply to railroads. In 1918, the Federal government effectively took control over operation of the nation's railroads to mobilize people, equipment and supplies for World War I. Also, the train dispatchers and traffic scheduling and planning personnel may work for the Federal government, as do most air traffic controllers, but Federal employment is not necessary. The model of the FAA Contract Tower Program could be used. Contract controllers are employees of private companies, but meet the same qualification and training requirements of FAA controllers and are subject to the same regulations and procedures.

Open Access:

In most European countries by the middle of the 20th century railroads were government owned vertically integrated monopolies. The European Union determined that a government monopoly was as detrimental as a private sector monopoly. In 1991, The European Union established a system of open access to the rail network through EU Council Directive 91/440/EEC of 29 July 1991. The directive required the separation of infrastructure from service regardless of ownership. Infrastructure and service may share ownership, but only as financially separate subsidiaries. The directive also requires non-discriminatory access to the infrastructure, using a fixed fee schedule applicable to all. Railroad infrastructure has effectively become toll roads for trains, generally called open access. The rail infrastructure operator of each country publishes a schedule of fees that apply to all users.

Passenger rail subsidiaries of the state-owned railroad companies in several European nations face direct

competition from either state-owned railroads of other European nations, private railroad ventures or both. Examples include the German Deutsche Bahn (DB); the Italian state-owned Trenitalia; the French state-owned SNCF Voyageurs; and in Spain Renfe operates Ave and Avlo in competition with SNCF operating Ouigo Espana, and with a private joint venture operating Iryo⁸⁴. In each of these countries the competing passenger trains operate on railroads owned and maintained by government-owned rail infrastructure companies DB Netz AG, RFI – Rete Ferroviaria Italiana (RFI), SNCF Réseau, and – Administrador de Infraestructuras Ferroviarias (ADIF).

In the EU, allocation of train paths for freight tends to be handled by the infrastructure subsidiary of each national rail company. RailNetEurope—an association of rail infrastructure managers funded by CINEA (European Climate Infrastructure and Environment Executive Agency)—facilitates allocation of train paths for international freight movements, and is developing a series of 11 international freight corridors. An approach to implementing open access in the U.S. might involve defining a network of rail corridors and setting up an independent agency to allocate train paths. This agency's role in the rail sector would be somewhat akin to the FAA's air traffic control function in the aviation sector. The EU regulations for open access do not appear to require that the infrastructure be owned by governments; they just require that they be independent of the train operating entities in terms of organization and decision-making, and have separate accounting systems⁸⁵. It seems likely that rail infrastructure in the EU will remain in government hands, just as highways and airports are for the most part in the EU and in North America. What would be necessary to implement open access in the U.S. is that the owners of the infrastructure be independent of the train operating entities in terms of organization and decision-making, and have separate accounting systems.

The companies that run the trains pay fees to the infrastructure companies of each country. The fee structure prescribed by EU regulations includes the cost of owning and operating the infrastructure and a profit margin. In certain circumstances, mark-ups (additional, what the market will bear charges) are allowed. When an infrastructure company has a need for additional infrastructure to accommodate additional traffic, a business case is made to the government. Grants are awarded for the new infrastructure, which becomes

84. <https://www.railway-technology.com/features/how-spain-became-the-arena-for-high-speed-rail-competition>

85. https://eur-lex.europa.eu/legal-content/EN/TXT/?uri=LEGISSUM%3A3203_2

property of the infrastructure owner upon completion. There is U.S. precedent for this arrangement in the way that passenger rail projects, particularly for commuter and corridor service, are implemented. The freight railroad makes a business case for the infrastructure needed on its right-of-way to support the new traffic. When the projects are complete, the new service operates and the new infrastructure becomes property of the railroad company.

There is precedent in the U.S. for this arrangement. Baltimore & Ohio Chicago Terminal (B&OCT) Railroad was a wholly owned subsidiary of Baltimore & Ohio Railroad. The purpose of separation was the ability to take advantage of benefits available to railroads located entirely within the Chicago Switching District. Each railroad using B&OCT, including Baltimore & Ohio, was charged a fee to use B&OCT tracks. The New Orleans Public Belt operates in a similar manner today, interchanging with six Class I railroads. Established in 1908 by the Port of New Orleans, its purpose is to give the major railroads “uniform and impartial” access to the port. New Orleans Public Belt also owns the most important and heavily used bridge over the Lower Mississippi River, which any railroad can freely use, even if they are just transferring freight over the Mississippi River and not accessing the Port of New Orleans. There are numerous other examples of joint use of tracks throughout the U.S., but under arrangements different from that of the EU. Generally, they are a concession that was required to complete a merger.

The EU approach to open access does not take advantage of the infrastructure owner, a fear that has been expressed by North American railroad companies when open access is discussed. On the contrary, it increases opportunities to generate additional return on infrastructure investment. The arrangement would be an advantage to the owners of greatly underutilized U.S. rail infrastructure and equipment. The nation has vast expanses of virtually empty rail lines and a relatively small number of extremely congested areas, generally due to operating and infrastructure minimalization practices.

The U.S. Constitution gives Congress the power to regulate interstate commerce and establish post roads. A subsequent Supreme Court decision stated that post roads could be used for other concurrent uses. In 1838, Congress designated all existing and future railroads as post roads. These precedents provide the perfect opportunity to vastly improve U.S. rail transportation through a toll road for trains open access arrangement like that in the EU. An open access, toll road for trains,

arrangement allows the railroad corporations to provide or discourage service as they currently do, while allowing other companies to provide the service that is now missing. The arrangement would provide alternative employment opportunities for people currently trapped in an unacceptable employment arrangement.

The arrangement could facilitate implementing new passenger rail service and would improve the punctuality of current passenger service. Prior to Amtrak, passenger trains carried a significant amount of express freight, most of which was lost to the government-supported competition of trucks. From the mid-1980s into the early 2000s Amtrak operated an extensive express freight service on passenger trains, but track access and schedule restrictions and opposition of the freight carriers caused the service to fail. Under the open access model, such service could return and provide the basis for new passenger rail service and improvements to the existing service.

While the U.S. ranks second in the world in total tons carried by rail, but ranks 40th in the world in terms of train-miles per mile of track. European countries run far higher numbers of train-miles per mile of track. For example, the German rail infrastructure company DB Netze has a mandate to reliably operate the maximum number of trains the infrastructure can accommodate. There are university programs throughout Europe for the study of maximizing rail infrastructure utilization. U.S. railroad management has focused on avoiding running trains, running as few long, heavy trains as possible to minimize costs.

Open access on the U.S. rail system would allow shippers equitable access to the railroads, involving the separation of infrastructure and operating functions of railroad companies. Accommodating the movement of lighter loads, shorter distances, and time-sensitive shipments by providing a fee-based system for rental of the railroads will increase competition, efficiency, and utilization, and will facilitate mode shift from highway to rail. Open access is essential for development of an effective and sustainable freight rail program.

There is an urgent need for substantially improved rail transportation in the U.S. Continuing with the current model will not do that. An open access rail infrastructure model like that of the EU is needed.

References

Thomas White, *The Climate Emergency; Trains – An Effective Response*, VTD Rail Publishing, 2020:

<http://www.vtd.net/VTDPUB/TCE/TCE.html>

UK Railway Industry Association, *Why Rail Electrification?* report, 2021

https://riagb.org.uk/RIA/Newsroom/Publications%20Folder/Why_Rail_Electrification_Report.aspx

Sierra Club National
2101 Webster Street, Suite 1300
Oakland, CA 94612
(415) 977-5500

Sierra Club Legislative
50 F Street, NW, Eighth Floor
Washington, DC 20001
(202) 547-1141

facebook.com/SierraClub
instagram.com/SierraClub
twitter.com/SierraClub

EXPLORE, ENJOY, AND PROTECT THE PLANET. **SIERRACLUB.ORG**

